

NO. E1CK-810

ISSUED: JUN. 28, 2010

REVISED: _____



**HOSHIZAKI
MODULAR CUBER**

**MODEL IM-240DNE
 IM-240DNE-C
 IM-240DWNE
 IM-240DWNE-C**

SERVICE MANUAL

CONTENTS

PAGE

I. SPECIFICATIONS -----	1
1. DIMENSIONS/SPECIFICATIONS-----	1
[a] IM-240DNE -----	1
[b] IM-240DNE-C -----	2
[c] IM-240DWNE-----	3
[d] IM-240DWNE-C -----	4
II. GENERAL INFORMATION -----	5
1. CONSTRUCTION -----	5
[a] IM-240DNE/XNE, IM-240DNE-C/XNE-C-----	5
[b] IM-240DWNE/XWNE, IM-240DWNE-C/XWNE-C -----	6
2. CONTROLLER BOARD -----	7
[a] CONTROLLER BOARD LAYOUT -----	8
[b] INPUT/OUTPUT LAYOUT -----	9
[c] BEFORE CHECKING CONTROLLER BOARD -----	10
III. OPERATING INSTRUCTIONS-----	11
1. START UP-----	11
2. PREPARING THE ICEMAKER FOR LONG STORAGE-----	12
3. BIN CONTROL-----	13
[a] BIN CONTROL SWITCH ASSEMBLY -----	13
[b] REMOVAL-----	14
IV. MAINTENANCE INSTRUCTIONS -----	15
1. PERIODICAL CLEANING -----	15
2. WATER VALVE-----	17
3. WATER-COOLED CONDENSER -----	18
4. ICEMAKING WATER SYSTEM-----	19
V. TECHNICAL INFORMATION-----	22
1. WATER CIRCUIT AND REFRIGERANT CIRCUIT-----	22
[a] IM-240DNE/XNE, IM-240DNE-C/XNE-C-----	22
[b] IM-240DWNE/XWNE, IM-240DWNE-C/XWNE-C -----	23
2. WIRING DIAGRAM -----	24
3. PERFORMANCE DATA-----	25
VI. SERVICE DIAGNOSIS -----	26
1. ERROR CODE INDICATION -----	26
2. NO ERROR CODE INDICATION-----	27
VII. ADJUSTMENT -----	29
1. EXPANSION VALVE -----	29
2. WATER REGULATING VALVE - WATER-COOLED MODEL ONLY-----	30

VIII. REMOVAL AND REPLACEMENT-----	31
1. SERVICE FOR REFRIGERANT LINES -----	31
[a] SERVICE INFORMATION -----	31
[b] REFRIGERANT RECOVERY -----	32
[c] EVACUATION AND RECHARGE -----	32
2. COMPRESSOR-----	33
3. DRIER -----	34
4. EXPANSION VALVE -----	35
5. EVAPORATOR -----	36
6. HOT GAS VALVE -----	37
7. WATER REGULATING VALVE - WATER-COOLED MODEL ONLY-----	38
[a] VALVE BODY -----	38
[b] WHOLE VALVE -----	38
8. WATER PAN ASSEMBLY -----	40
9. PUMP MOTOR-----	42
10. WATER VALVE-----	42
11. ACTUATOR MOTOR -----	43
12. CAM ARM -----	43
[a] CAM ARM (A) - ACTUATOR MOTOR SIDE-----	43
[b] CAM ARM (B) - REAR SIDE -----	43
13. CONTROLLER BOARD -----	46
14. THERMISTOR FOR CUBE CONTROL-----	48
15. FAN MOTOR - DNE(-C)/XNE(-C) ONLY -----	49

I. SPECIFICATIONS

1. DIMENSIONS/SPECIFICATIONS

[a] IM-240DNE (Air-cooled)

ITEM	Hoshizaki Ice Maker IM-240DNE
MODEL	IM-240DNE
AC SUPPLY VOLTAGE	1 Phase 220-240V 50Hz
AMPERAGE	6.4A (AT.32C, WT.21C)
STARTING AMPERAGE	31A
ELECTRIC CONSUMPTION	1.330W (AT.32C, WT.21C)
POWER FACTOR	86%
POWER SUPPLY CAPACITY	Min. 2.1KVA (8.8A)
ICE PRODUCTION PER 24h	Approx. 230kg (5mm)/240kg (15mm) (AT.10C, WT.10C)
	Approx. 220kg (5mm)/230kg (15mm) (AT.21C, WT.15C)
	Approx. 200kg (5mm)/210kg (15mm) (AT.32C, WT.21C)
	Approx. 0.76m ³ /d (AT.10C, WT.10C)
WATER CONSUMPTION PER 24h	Approx. 0.38m ³ /d (AT.21C, WT.15C)
	Approx. 0.35m ³ /d (AT.32C, WT.21C)
	Approx. 0.35m ³ /d (AT.32C, WT.21C)
SHAPE OF ICE	Cube Approx. 28x28x32mm
FREEZE CYCLE TIME	Approx. 21min (AT.21C, WT.15C)
ICE PRODUCTION PER CYCLE	Approx. 3.2kg/140pcs (AT.21C, WT.15C)
DIMENSIONS	1084mm(W)x700mm(D)x500mm(H)
EXTERIOR	Stainless Steel
CONNECTIONS-ELECTRIC	X-Type Con. (with CONT. Plug)
CONNECTIONS-WATER SUPPLY	Inlet G3/4 (connected at left side)
CONNECTIONS-DRAIN	Outlet R3/4 (connected at left side)
ICE MAKING SYSTEM	Cell type
HARVESTING SYSTEM	Hot Gas Defrost
COMPRESSOR	Hermetic 970W Model RS80C2E
CONDENSER	Air-cooled, Fin and Tube type
HEAT REJECTION	2750W(2365kcal/h) (AT.32C, WT.21C)
EVAPORATOR	Tin-plated Copper Tube on Sheet and Cells
REFRIGERANT CONTROL	Thermostatic Expansion Valve
REFRIGERANT CHARGE	R404A/470g
ICE MAKING CONTROL	Thermistor, Timer
	Thermistor
BIN CONTROL	Microswitch with Time Delay
ICE MAKING WATER CONTROL	Timer, Water Pan's movement
ELECTRICAL PROTECTION	Class I Appliance, 5A Fuse
COMPRESSOR PROTECTION	Auto-reset Overload Protector
ICE MAKER PROTECTION	Interlock by Controller Board
WEIGHT	Net weight 88kg/Gross weight 106kg
PACKAGE	Carton 1196mm(W)x825mm(D)x640mm(H)
ACCESSORIES	Scoop, Installation Kit, Brace
OPERATING CONDITIONS	Ambient Temp.: 1 - 40° C, Water Supply Temp.: 5-35C Water Supply Pressure: 0.3-7.8bar(0.03-0.78Mpa), Voltage Range: Rated Voltage±5%

*We reserve the right to make changes in specifications and design without prior notice.

1. Install the ice maker properly in accordance with the instructions on location, water supply/drain connections and electrical connections stated in the instruction and installation manuals provided. Allow 10mm extra space at the installation site to meet any installation requirements (additional spacing is also required for proper air flow and water connections).
2. The ice production depends on the ambient and water temperatures.
Refer to the instruction manual.
3. Product Code: E7CK

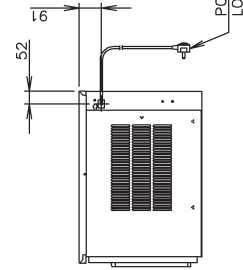
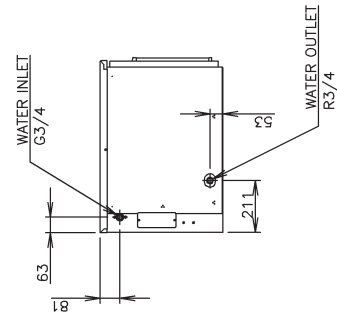
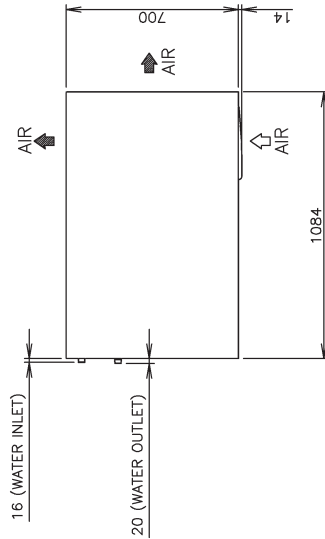

[b] IM-240DNE-C (Air-cooled)

1. Install the ice maker properly in accordance with the instructions on location, water supply/drain connections and electrical connections stated in the instruction and installation manuals provided. Allow 10mm extra space at the installation site to meet any installation requirements (additional spacing is also required for proper air flow and water connections).
2. The ice production depends on the ambient air flow and water connections.
3. Refer to the instruction manual.

Product Code: E1CK-D001

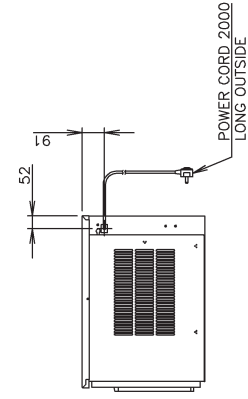
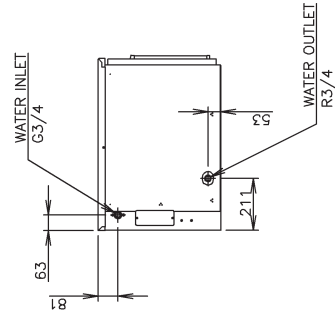
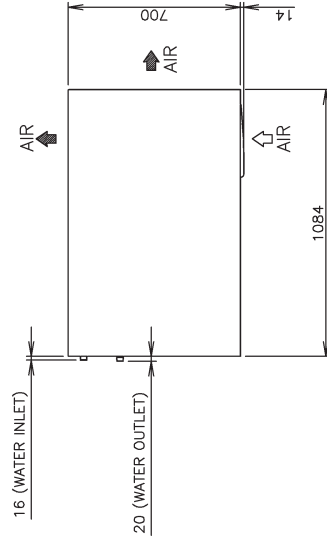

ITEM	Hoshizaki Ice Maker
MODEL	IM-240DNE-C
AC SUPPLY VOLTAGE	1 Phase 220-240V 50HZ
AMPERAGE	6.4A (AT.32C, WT.21C)
STARTING AMPERAGE	31A
ELECTRIC CONSUMPTION	1.330W (AT.32C, WT.21C)
POWER FACTOR	86%
POWER SUPPLY CAPACITY	Min. 2.1KVA (8.8A)
ICE PRODUCTION PER 24H	Approx. 210kg (10mm)/240kg (20mm) (AT.10C, WT.10C) Approx. 190kg (10mm)/220kg (20mm) (AT.21C, WT.15C) Approx. 170kg (10mm)/190kg (20mm) (AT.32C, WT.21C)
WATER CONSUMPTION PER 24H	Approx. 0.68m ³ /d (AT.10C, WT.10C) Approx. 0.31m ³ /d (AT.21C, WT.15C) Approx. 0.28m ³ /d (AT.32C, WT.21C)
SHAPE OF ICE	Cube Approx. ϕ 37 x H45mm
FREEZE CYCLE TIME	Approx. 25min (AT.21C, WT.15C)
ICE PRODUCTION PER CYCLE	Approx. 3.3kg/72pcs (AT.21C, WT.15C)
DIMENSIONS	1084mm(W)x700mm(D)x500mm(H)
EXTERIOR	Stainless Steel
CONNECTIONS-ELECTRIC	X-Type Con. (with CONT. Plug)
CONNECTIONS-WATER SUPPLY	Inlet G3/4 (connected at left side)
CONNECTIONS-DRAIN	Outlet R3/4 (connected at left side)
ICE MAKING SYSTEM	Cell type
HARVESTING SYSTEM	Hot Gas Defrost
COMPRESSOR	Hermetic
CONDENSER	Air-cooled, Fin and Tube type
HEAT REJECTION	2750W(2365kcal/h) (AT.32C, WT.21C)
EVAPORATOR	Tin-plated Copper Tube on Sheet and Cells
REFRIGERANT CONTROL	Thermostatic Expansion Valve
REFRIGERANT CHARGE	R404A
ICE MAKING CONTROL	Thermistor, Timer
HARVESTING CONTROL	Thermistor
BIN CONTROL	Microswitch with Time Delay
ICE MAKING WATER CONTROL	Timer, Water Pan's movement
ELECTRICAL PROTECTION	Class I Appliance, 5A Fuse
COMPRESSOR PROTECTION	Auto-reset Overload Protector
ICE MAKER PROTECTION	Interlock by Controller Board
WEIGHT	Net weight 89kg/Gross weight 106kg
PACKAGE	Carton 1196mm(W)x825mm(D)x640mm(H)
ACCESSORIES	Scoop, Installation Kit, Brace
OPERATING CONDITIONS	Ambient Temp.: 1 - 40° C, Water Supply Temp.: 5-35C Water Supply Pressure: 0.5-7.0bar(0.05-0.7MPa), Voltage Range: Rated Voltage±5%

*We reserve the right to make changes in specifications and design without prior notice.

[c] IM-240DWNE (Water-cooled)

1. Install the ice maker properly in accordance with the instructions on location, water supply/drain connections and electrical connections stated in the instruction and installation manuals provided. Allow 10mm extra space at the installation site to meet any installation requirements (additional spacing is also required for proper air flow and water connections).
2. The ice production depends on the ambient and water temperatures. Refer to the instruction manual.
3. Values for ice making water only. Use a cooling tower for cooling water.
4. Product Code: ETCL

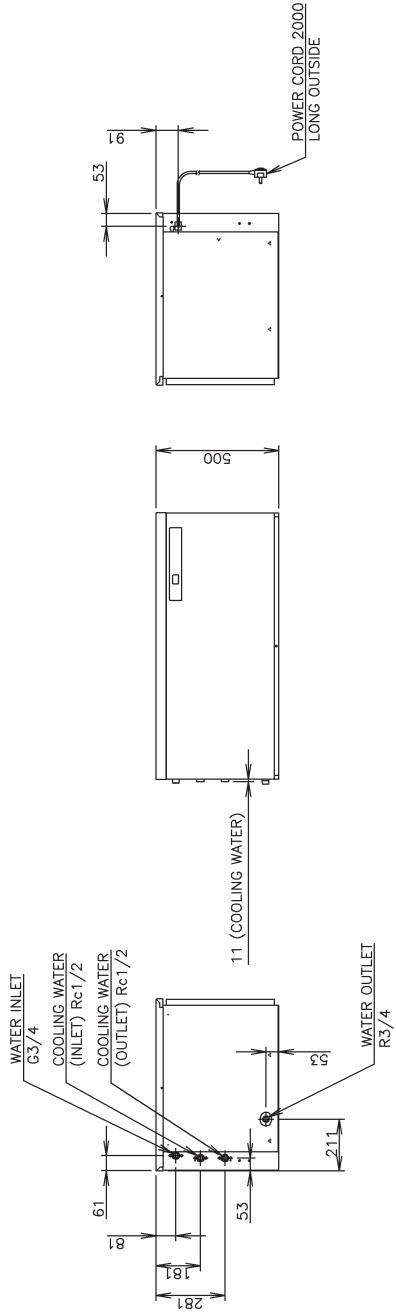
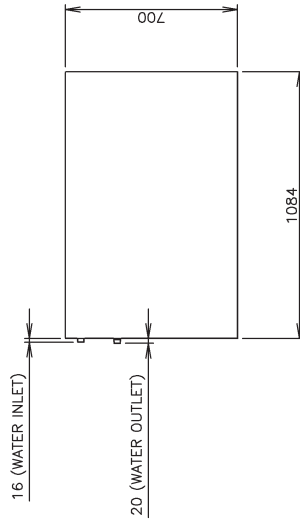

ITEM	Hoshizaki Ice Maker
MODEL	IM-240DWNE
AC SUPPLY VOLTAGE	1 Phase 220-240V 50Hz
AMPERAGE	5.8A (AT.32c, WT.21c)
STARTING AMPERAGE	31A
ELECTRIC CONSUMPTION	1.300W (AT.32c, WT.21c)
POWER FACTOR	93%
POWER SUPPLY CAPACITY	Min. 2.1KVA (8.8A)
ICE PRODUCTION PER 24H	Approx. 225(5mm)/235(15mm)kg (AT.10c, WT.10c)
	Approx. 202(5mm)/215(15mm)kg (AT.21c, WT.15c)
	Approx. 196(5mm)/200(15mm)kg (AT.32c, WT.21c)
WATER CONSUMPTION PER 24H	Approx. 0.74m ³ (AT.10c, WT.10c)
#3	Approx. 0.35m ³ (AT.21c, WT.15c)
	Approx. 0.34m ³ (AT.32c, WT.21c)
SHAPE OF ICE	Cube Approx. 28x28x32mm
FREEZE CYCLE TIME	Approx. 25min (AT.21c, WT.15c)
ICE PRODUCTION PER CYCLE	Approx. 3.2kg/140pcs (AT.21c, WT.15c)
DIMENSIONS	1084mm(W)x700mm(D)x500mm(H)
EXTERIOR	Stainless Steel
CONNECTIONS-ELECTRIC	X-Type Con. (with CONT. Plug)
CONNECTIONS-WATER SUPPLY	Inlet G3/4 (connected at left side)
CONNECTIONS-DRAIN	Outlet R3/4 (connected at left side)
CONNECTIONS-COOLING WATER	Inlet Rc1/2 (connected at left side) Outlet Rc1/2 (connected at left side)
ICE MAKING SYSTEM	Cell type
HARVESTING SYSTEM	Hot Gas Defrost
COMPRESSOR	Hermetic
CONDENSER	Water-Cooled, Tube in Tube type
HEAT REJECTION	2490W(2145kcal/h) (AT.32c, WT.21c)
EVAPORATOR	Tin-plated Copper Tube on Sheet and Cells
REFRIGERANT CONTROL	Thermostatic Expansion Valve
REFRIGERANT CHARGE	R404A
ICE MAKING CONTROL	Thermistor, Timer
HARVESTING CONTROL	Thermistor
BIN CONTROL	Microswitch with Time Delay
ICE MAKING WATER CONTROL	Timer, Water Pan's movement
ELECTRICAL PROTECTION	Class I Appliance, 5A Fuse
COMPRESSOR PROTECTION	Auto-reset Overload Protector
ICE MAKER PROTECTION	Interlock by Controller Board
WEIGHT	Net weight 87kg/Gross weight 105kg
PACKAGE	Carton 1196mm(W)x825mm(D)x640mm(H)
ACCESSORIES	Scoop, Installation Kit, Brace
OPERATING CONDITIONS	Ambient Temp.: 1 - 40° C, Water Supply Temp.: 5 - 35° C Water Supply Pressure: 0.5 - 7.0bar(0.05 - 0.7MPa), Voltage Range: Rated Voltage±5%

*We reserve the right to make changes in specifications and design without prior notice.

[d] IM-240DWNE-C (Water-cooled)

1. Install the ice maker properly in accordance with the instructions on location, water supply/drain connections and electrical connections stated in the instruction and installation manuals provided. Allow 10mm extra space at the installation site to meet any installation requirements (additional spacing is also required for proper air flow and water connections).
2. The ice production depends on the ambient and water temperatures. Refer to the instruction manual.
3. Values for ice making water only. Use a cooling tower for cooling water.
4. Product Code: E1ICL-D001

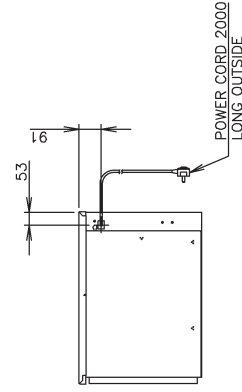
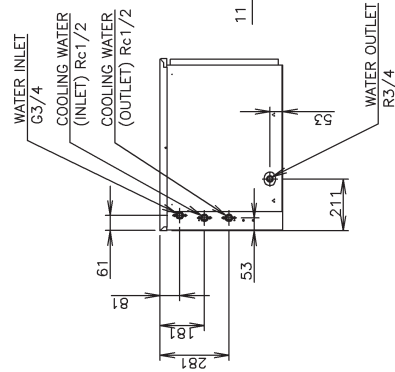
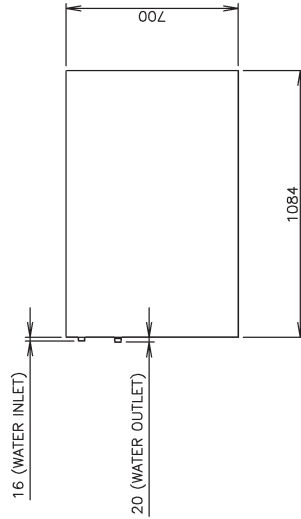

ITEM	Hoshizaki Ice Maker
MODEL	IM-240DWNE-C
AC SUPPLY VOLTAGE	1 Phase 220-240V 50Hz
AMPERAGE	5.8A (AT.32°C, WT.21°C)
STARTING AMPERAGE	31A
ELECTRIC CONSUMPTION	1300W (AT.32°C, WT.21°C)
POWER FACTOR	93%
POWER SUPPLY CAPACITY	Min. 2.1KVA (8.8A)
ICE PRODUCTION PER 24h	Approx. 200(10mm)/235(20mm)kg (AT.10°C, WT.10°C) Approx. 190(10mm)/200(20mm)kg (AT.21°C, WT.15°C) Approx. 180(10mm)/190(20mm)kg (AT.32°C, WT.21°C)
WATER CONSUMPTION PER 24h	Approx. 0.63m ³ (AT.10°C, WT.10°C) Approx. 0.31m ³ (AT.21°C, WT.15°C) Approx. 0.30m ³ (AT.32°C, WT.21°C)
SHAPE OF ICE	Cube Approx. φ 37×H45mm
FREEZE CYCLE TIME	Approx. 25min (AT.21°C, WT.15°C)
ICE PRODUCTION PER CYCLE	Approx. 3.3kg/72pcs (AT.21°C, WT.15°C)
DIMENSIONS	1084mm(W)×700mm(D)×500mm(H)
EXTERIOR	Stainless Steel
CONNECTIONS-ELECTRIC	X-Type Con. (with CONT. Plug)
CONNECTIONS-WATER SUPPLY	Inlet G3/4 (connected at left side)
CONNECTIONS-DRAIN	Outlet R3/4 (connected at left side)
CONNECTIONS-COOLING WATER	Inlet Rc1/2 (connected at left side) Outlet Rc1/2 (connected at left side)
ICE MAKING SYSTEM	Cell type
HARVESTING SYSTEM	Hot Gas Defrost
COMPRESSOR	Hermetic
CONDENSER	Water-Cooled, Tube in Tube type
HEAT REJECTION	2490W(2145kcal/h) (AT.32°C, WT.21°C)
EVAPORATOR	Tin-plated Copper Tube on Sheet and Cells
REFRIGERANT CONTROL	Thermostatic Expansion Valve
REFRIGERANT CHARGE	R404A
ICE MAKING CONTROL	Thermistor, Timer
HARVESTING CONTROL	Thermistor
BIN CONTROL	Microswitch with Time Delay
ICE MAKING WATER CONTROL	Timer, Water Pan's movement
ELECTRICAL PROTECTION	Class I Appliance, 5A Fuse
COMPRESSOR PROTECTION	Auto-reset Overload Protector
ICE MAKER PROTECTION	Interlock by Controller Board
WEIGHT	Net weight 88kg/Gross weight 106kg
PACKAGE	Carton 1196mm(W)×825mm(D)×640mm(H)
ACCESSORIES	Scoop, Installation Kit, Brace
OPERATING CONDITIONS	Ambient Temp.: 1 - 40° C, Water Supply Temp.: 5-35°C Water Supply Pressure: 0.5-7.8bar(0.05-0.78MPa) Voltage Range: Rated Voltage±5%

*We reserve the right to make changes in specifications and design without prior notice.

II. GENERAL INFORMATION

1. CONSTRUCTION

[a] IM-240DNE/XNE, IM-240DNE-C/XNE-C

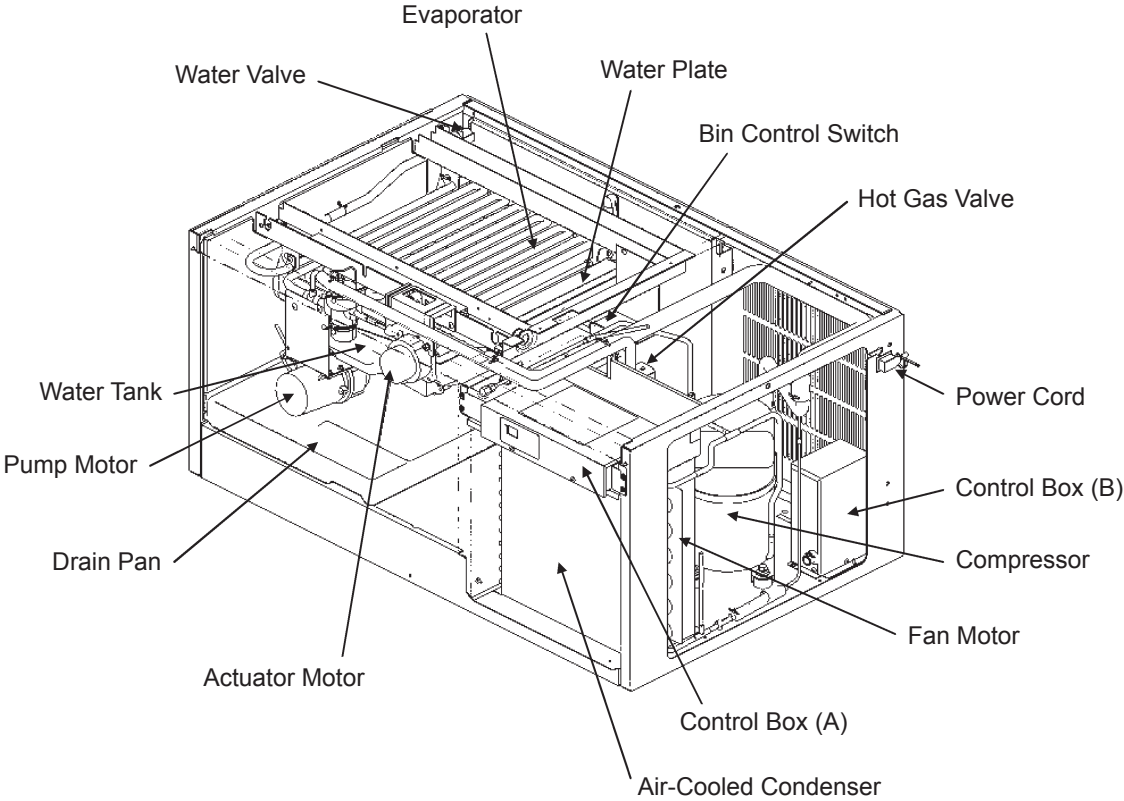
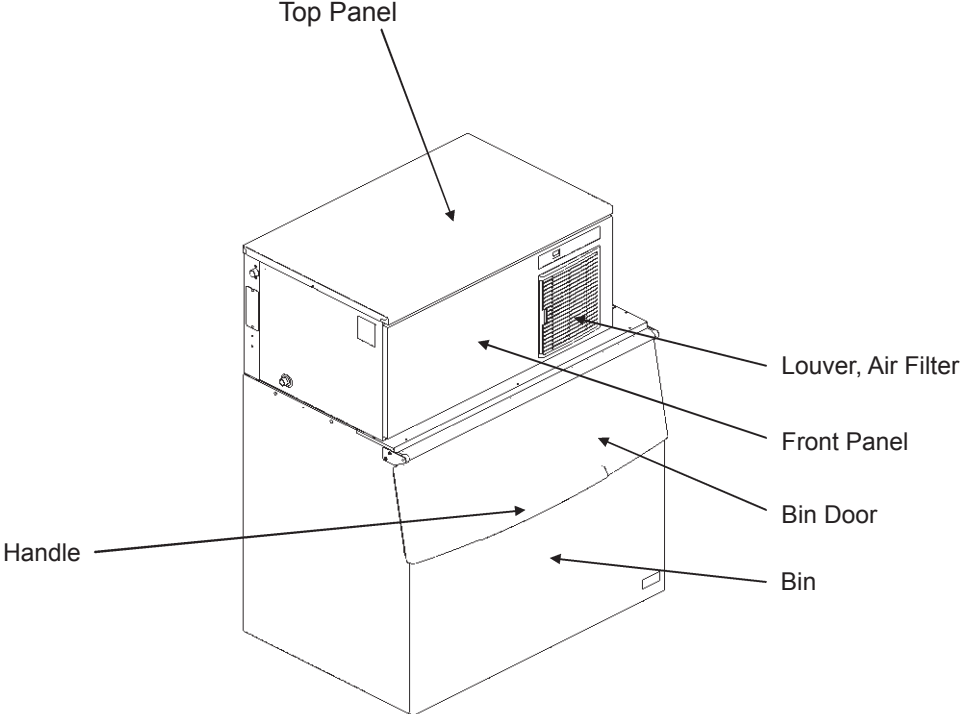

[b] IM-240DWNE/XWNE, IM-240DWNE-C/XWNE-C (Water-cooled)

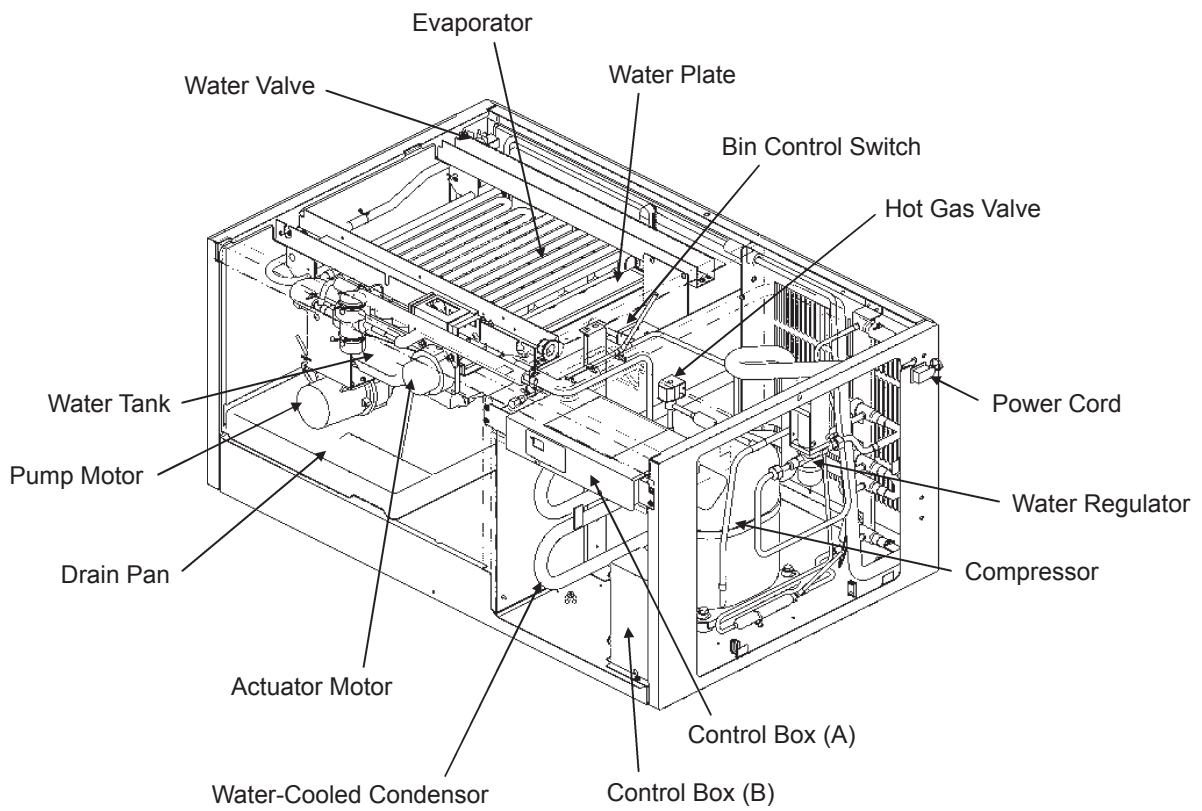
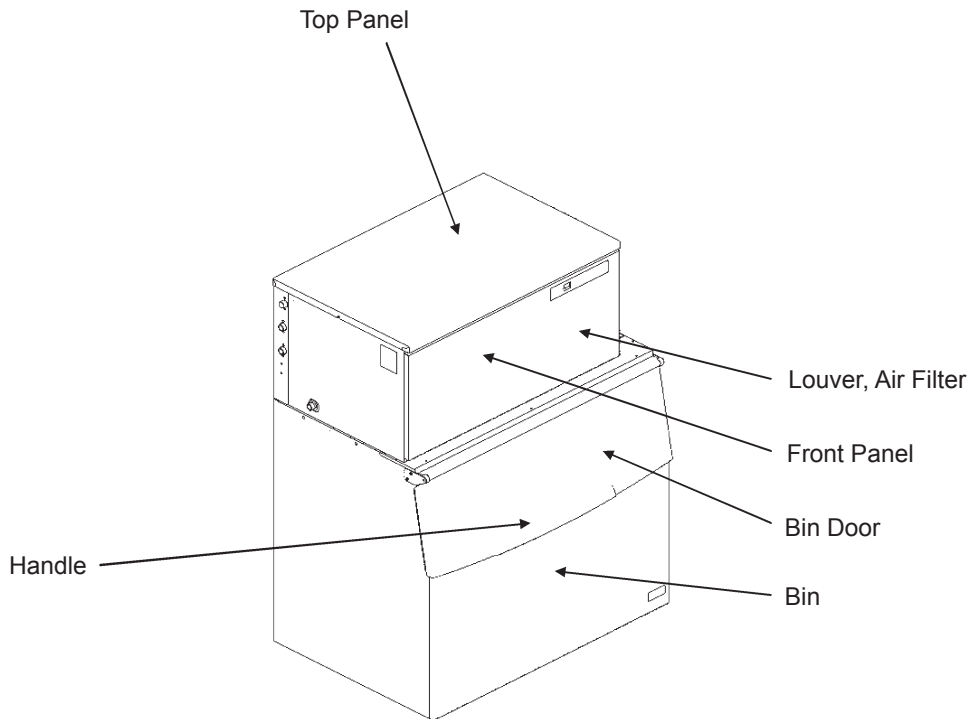

2. CONTROLLER BOARD

Note: Refer to the Controller Board Service Manual.

IMPORTANT

If receiving a service call, ask the user to turn off the power to the icemaker and turn it on again, while watching the icemaker. This will reset the controller, and in some cases normal operation will resume.

CAUTION

1. Check that the icemaker has been earthed properly. If not, the Controller Board will not work properly.
2. Do not change wiring and connections, or the Controller Board will not work properly.
3. Do not touch the reverse side of the Controller Board and tiny electronic devices on it.
4. Do not repair the electronic devices and parts on the Controller Board in the field (except for fuse replacement). Replace the whole board assembly when it fails.
5. To get static free, always touch the metal part of the icemaker before servicing. Electrostatic Discharge will cause severe damage to the Controller Board.
6. The Signal Ground Wire must be connected to the Control Box when replacing the Controller Board after service.
7. The Controller Board is fragile. Handle with care.
 - * Do not drop the board on the floor.
 - * Make sure that the board is placed correctly into the guides in the Control Box. Mis-alignment could cause breakage when replacing the Control Box Cover.
 - * Handle the board by the edges only. Do not touch the electric parts and devices.

[b] INPUT/OUTPUT LAYOUT

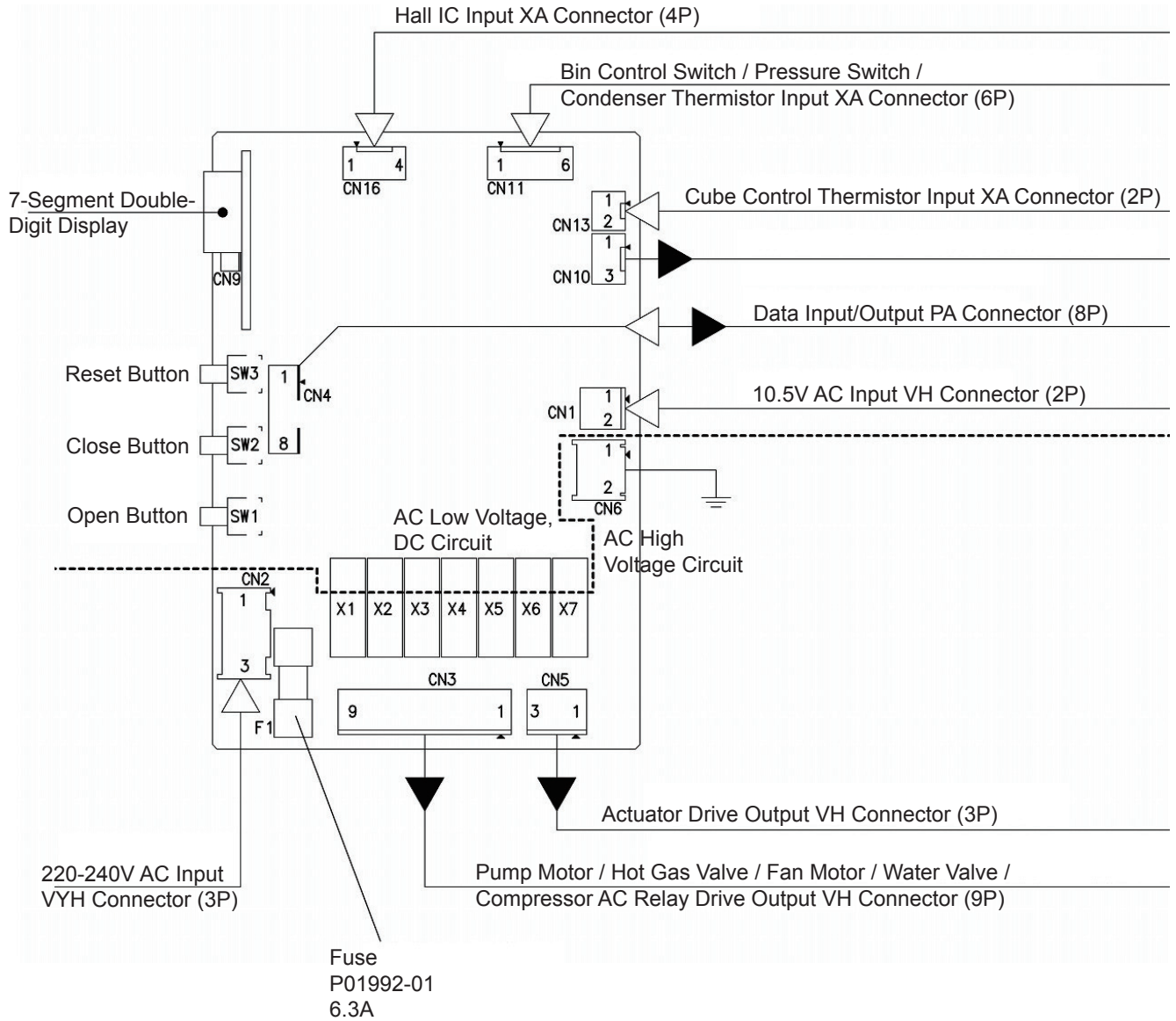

[c] BEFORE CHECKING CONTROLLER BOARD

Check the power source voltage and the components as shown in the table below.

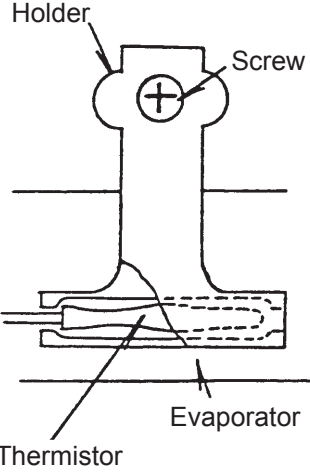
Component	Procedure	Normal
<p>1. Thermistor (on Evaporator)</p> 	<div style="border: 1px solid black; padding: 5px; margin-bottom: 10px;"> <p style="text-align: center;">CAUTION</p> <p>Thermistor Sensor part is fragile, glass sealed. Handle with care.</p> </div> <ul style="list-style-type: none"> * Disconnect the Connector CN13 on the board. * Remove the screw and the Thermistor Holder on the Evaporator. * Immerse the Sensor part in a glass containing ice and water for 5 minutes. * Check the resistance between CN13 Connector Pins. * Replace the Thermistor in its correct position. * Connect CN13. 	<p>5 -7 kilohms</p>
<p>2. Bin Control Switch</p>	<p>Manually set the Micro Switch in the TRIP and RESET positions, and check the period.</p>	<p>Approx. TRIP(Closed) 10 sec. RESET(Open) 80 sec.</p>

III. OPERATING INSTRUCTIONS

WARNING

1. This icemaker is designed to produce and store edible ice. To keep the icemaker hygienic:
 - * Wash your hands before removing ice. Use the Plastic Scoop provided (accessory).
 - * The Storage Bin is for ice use only. Do not store anything else in the Bin.
 - * Clean the Storage Bin before use (see "IV. 1. PERIODICAL CLEANING").
 - * Keep the Scoop clean. Clean it by using a neutral cleaner and rinse thoroughly.
 - * Close the Door after removing ice to prevent entrance of dirt, dust or insects into the Storage Bin.

2. The use of any electrical equipment involves the observance of some fundamental rules. In particular:
 - * Instances of high humidity and moisture increase the risk of electrical short circuits and potential electrical shocks. If in doubt, disconnect the icemaker.
 - * Do not pull the power cord in order to disconnect the icemaker from the feed network.
 - * This appliance is not suitable for unsupervised use by young children or aged or infirm persons.

3. All parts are factory-adjusted. Improper adjustments may result in failure.

4. If the unit is turned off, wait for at least 3 minutes before restarting the icemaker to prevent damage to the Compressor.

5. Do not put your hands into the back of the Storage Bin or the Ice Chute on top of the Storage Bin. Ice may drop off the icemaker, a hard block of ice may suddenly break down, or the icemaking mechanism may suddenly move, resulting in injury.

1. START UP

- 1) Disconnect the power supply.
- 2) Open the water tap.
- 3) Connect the power supply and energise.

- 4) The following should occur in sequence:
 - a) Hot Gas Valve will open.
 - b) Compressor will start.
 - c) Water Pan will fully open.
 - d) Water Valve will open.
 - e) Water Pan will start to close (Hot Gas Valve closed).
 - f) Water Pan fully closed - Pump Motor will start.
 - g) Water Valve will close.

2. PREPARING THE ICEMAKER FOR LONG STORAGE

WARNING

Drain the icemaker to prevent damage to the water supply line at subfreezing temperatures, using air or carbon dioxide. Shut off the icemaker until proper air temperature is resumed.

- 1) Close the water supply tap, and remove the Inlet Hose.
- 2) Remove the Front Panel.
- 3) Remove the screw located on the front of the Water Tank.
- 4) Move the Tank Drain Pipe to the drain position. See Fig. 1.
- 5) Push the Reset Switch. The Water Pan will start to open.
- 6) Blow out the water supply line immediately after the Water Pan has opened.

Note: This procedure is necessary to protect the icemaker from freezing up at subfreezing temperature.

- 7) Unplug the icemaker or disconnect the power source when the Water Pan has fully opened.
- 8) Move the Tank Drain Pipe to the normal position, and secure it with the screw.
- 9) Remove all ice from the Storage Bin, and clean the Bin.

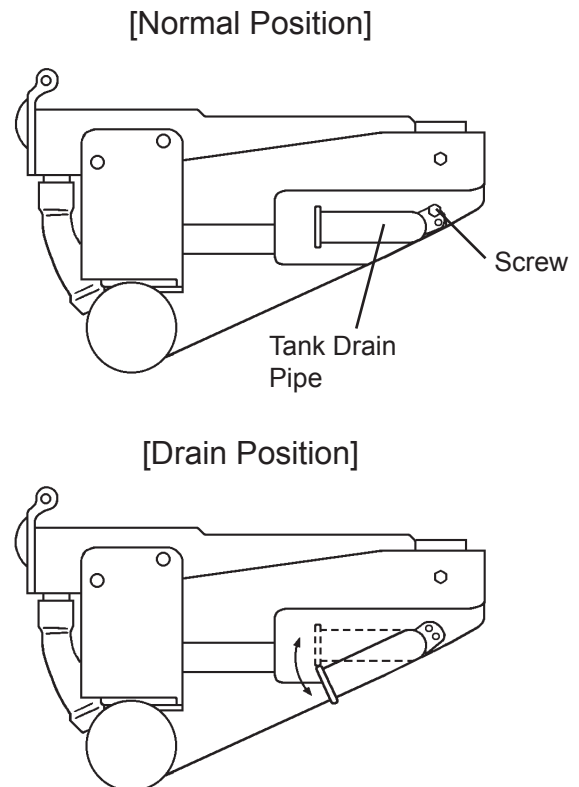

Fig. 1

10) Replace the panels in their correct positions.

11) Replace the Inlet Hose in its correct position.

3. BIN CONTROL

Bin Control Switch is mounted on the upper side of the Storage Bin. This switch will turn off the unit automatically when the Storage Bin is full of ice. Handle the Bin Control Switch carefully, because the switch assembly is fragile. Especially on removing ice, do not touch or poke with a scoop. Keep away from the Water Plate or Drain Pan to prevent jamming.

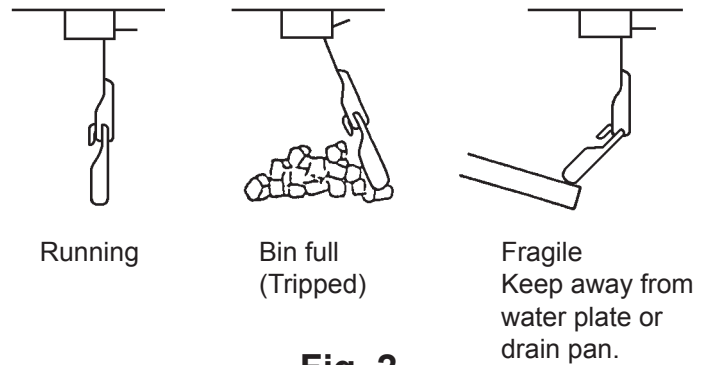

Fig. 2

[a] BIN CONTROL SWITCH ASSEMBLY

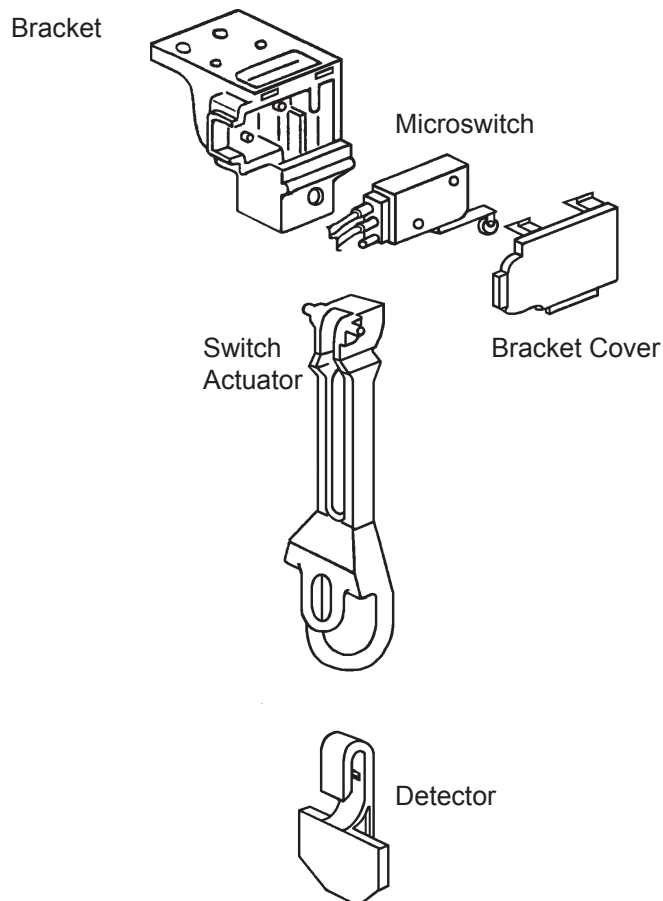
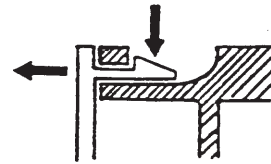

Fig. 3

[b] REMOVAL

BRACKET COVER

Push the two Pawls and remove the Bracket Cover.



SWITCH

Pull out the Switch, holding the Rubber Leads Cap. Handle with care.

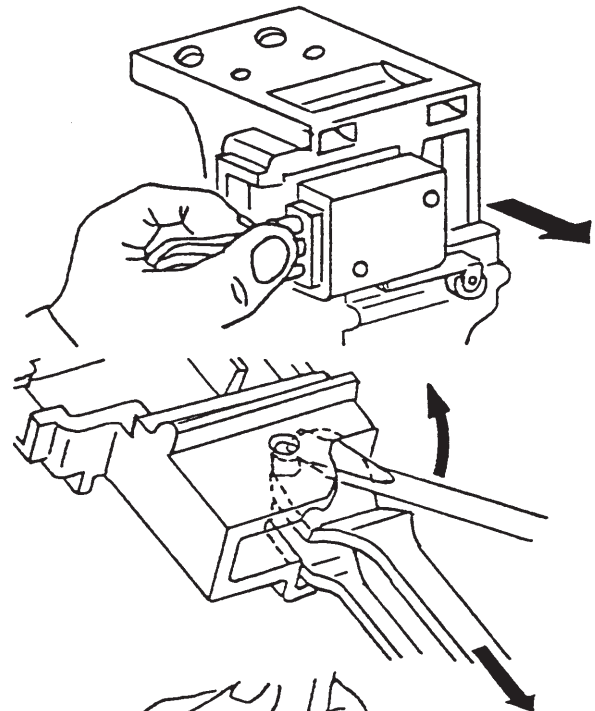

SWITCH ACTUATOR

Insert a flat blade screwdriver and wrench it slightly to pull out the Switch Actuator. Handle with care to prevent damage to the cam surface of the Actuator.



DETECTOR

Push out the Detector, holding the Switch Actuator.

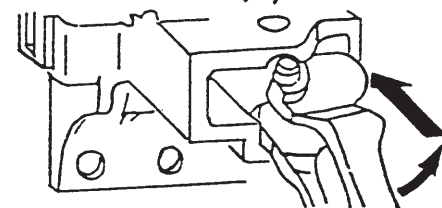

[c] REASSEMBLING

SWITCH ACTUATOR

Insert the lower Shaft and push it along the U Notch. Check that the Switch Actuator moves free.

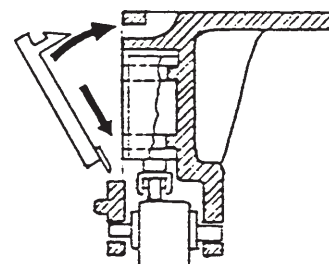

SWITCH & BRACKET COVER

Place the Switch Lever first, and then attach the Switch in position. Insert the guide and push the Bracket Cover to lock.

Fig. 4

IV. MAINTENANCE INSTRUCTIONS

WARNING

1. Before carrying out any cleaning or maintenance operations, unplug the icemaker from the electrical supply network.
2. Before handling or using cleaning solutions, check the guidelines on the product for advice on suitable personal protective clothing, gloves, goggles, etc.
3. Clean and sanitize the icemaker water system at least twice a year, and check and clean the Condenser at least once a year.
4. This appliance must not be cleaned by use of a water jet.

1. PERIODICAL CLEANING

[1] Machine and Bin Exterior

Wipe the exterior at least once per week with a clean, soft cloth. Use a damp cloth containing a neutral cleaner to wipe off grease or dirt.

[2] Scoop and Storage Bin Handle Cleaning/Sanitisation (Daily)

- 1) Either mix 3 litres of water with 11 ml of 5.25% sodium hypochlorite solution in a suitable container, or the recommended Hoshizaki sanitiser as directed.
- 2) Soak the Scoop in the solution for more than 3 minutes. Rinse thoroughly, and shake to remove surplus liquid.

Note: Using a cloth to dry may re-contaminate.

- 3) Use a neutral cleaner to wash the Storage Bin Handle. Rinse thoroughly.
- 4) Soak a clean cloth with the sanitising solution, and wipe the Handle. Use fresh water and a clean cloth to rinse/dry.

[3] Storage Bin Interior Cleaning/Sanitisation (Weekly)

- 1) Open the Storage Bin Door, and remove all ice.

Note: Hoshizaki recommends various types of Storage Bin for the icemaker which vary in size and design. The following instructions are therefore for general guidance only.

- 2) Wash the Bin liner, Ice Deflector and Door inner surface with a neutral non-abrasive cleaner. Rinse thoroughly with a clean cloth and fresh water.
- 3) Either mix 5 litres of water with 18 ml of 5.25% sodium hypochlorite solution in a suitable container, or the recommended Hoshizaki sanitiser as directed.
- 4) Soak a clean sponge or cloth with the solution, and wipe the Bin liner, Ice Deflector and Door inner surface.
- 5) Rinse thoroughly with fresh water and a clean cloth to wipe off the solution. Close the Bin Door.

Note: Some solutions may cause damage to the Bin liner surfaces or corrosion on the metal parts. Always rinse the sanitiser unless directed otherwise by Hoshizaki guidelines.

[4] Air Filter (Air-Cooled Model Only)

Plastic mesh Air Filters remove dirt or dust from the air, and keep the Condenser from getting clogged. If the Filters get clogged, the icemaker's performance will be reduced. Remove and clean the Air Filters at least twice per month:

- 1) Slide the Air Filter off the Louver.
- 2) Clean the Air Filter by using a vacuum cleaner. When severely clogged, use warm water and a neutral cleaner to wash the Air Filter.
- 3) Rinse and dry the Air Filter thoroughly, and place it in position.

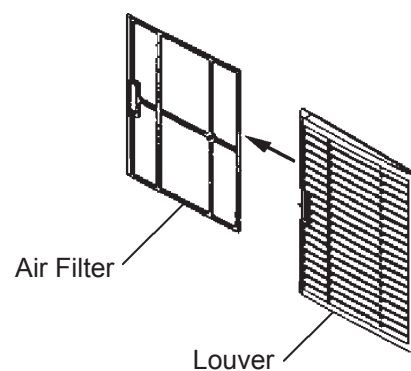

Fig. 5

2. WATER VALVE

- 1) Unplug the icemaker or disconnect the power source.
- 2) Close the water supply tap.
- 3) Remove the Top Panel and Front Panel.
- 4) Disconnect the Inlet Hose from the Water Valve.
- 5) Remove the Mesh Filter from the Water Valve.
- 6) Clean the Mesh using a brush.
- 7) Replace the Mesh and Inlet Hose in their correct positions.
- 8) Open the Shut-off Valve.
- 9) Plug in the icemaker or connect the power source.
- 10) Check for leaks.
- 11) Replace the panels in their correct positions.

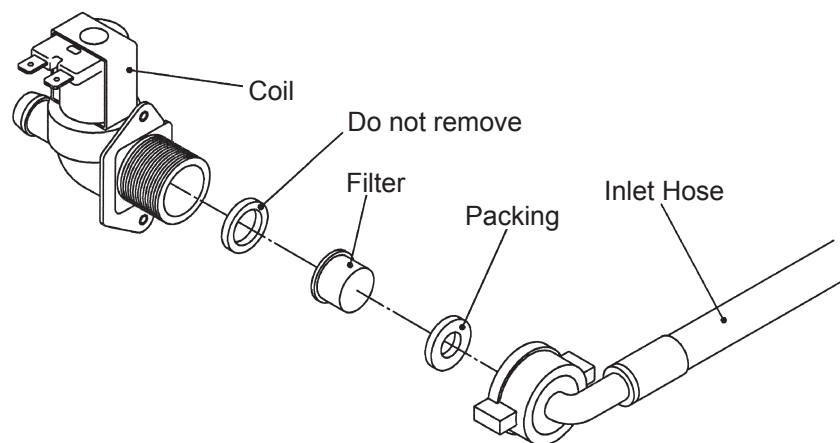

Fig. 6

3. WATER-COOLED CONDENSER

Deposits inside the water circuit of the Water-cooled Condenser decrease cooling performance. Clean inside of the Condenser by circulating a cleaning solution.

1) Prepare the following:

Cleaning solution [Read and follow any instructions on label or bottle.]

Pump Container for solution Hose Hose bands

Two fittings [R1/2 - 3/8" DIA] Two fittings [3/8" flare - 3/8" DIA]

CAUTION

Do not use a cleaning solution that will corrode the copper tubing.
In case of contact with the solution, flush with water.

- 2) Remove the panels and check for leaks from the water line.
- 3) Unplug the icemaker or disconnect the power source, and close the water supply tap.
- 4) Disconnect the cooling water inlet and outlet pipings and attach fittings to connect hoses.
- 5) Disconnect the inlet and outlet tubings of the Water Regulator and replace the Water Regulator by fittings.
- 6) Connect hoses as shown in Fig. 7 and secure them by hose bands.

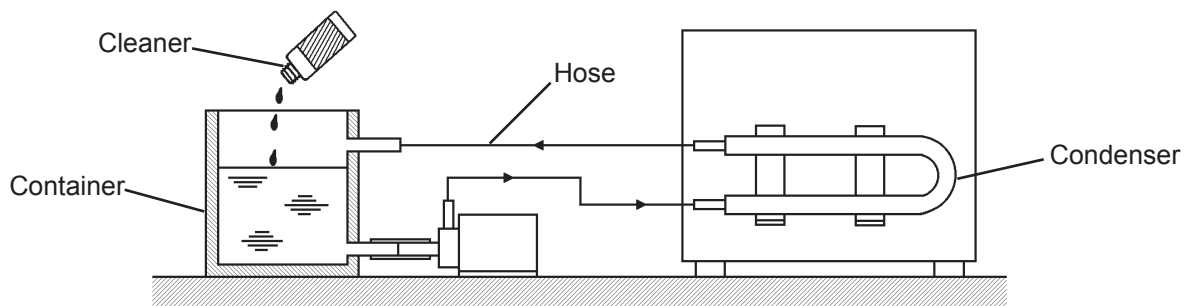

Fig. 7

- 7) Fill the container with the cleaning solution.
- 8) Run the pump motor and circulate the solution for a period recommended in the instructions on label or bottle of the cleaner.
- 9) Rinse the water circuit.

10) Reverse the above procedure in steps 2) through 6).

11) Check the icemaking capacity referring to “V. 3. PERFORMANCE DATA”.

4. ICEMAKING WATER SYSTEM

To keep the icemaker hygienic, clean and sanitize the icemaking water system at least once every six months. More frequent cleaning and sanitizing may be required depending on the water quality.

CAUTION

1. Always wear rubber gloves, eye protectors, apron, etc. for safe handling of the cleaner and sanitizer.
2. Use the cleaners and sanitizers recommended by Hoshizaki. Contact your local Hoshizaki office for further details. (The instructions below give an example of those recommended cleaners and sanitizers.)
3. Never mix cleaning and sanitizing solutions in an attempt to shorten cleaning time.
4. Wipe off any splashed or spilt cleaner/sanitizer immediately.
5. Do not use any ammonia type cleaners on any part of the icemaker.
6. When the ambient and water temperatures are 10°C or below, the Water Pan may remain open. Warm the icemaking compartment up to 20°C around the Thermistor.
7. Be sure to follow the cleaning and sanitizing instructions below.

- 1) Use a suitable container to dilute 236 ml of the cleaner (“Nickel-Safe Ice Machine Cleaner” by The Rectorseal Corporation) with 11.4 lit. of water.
- 2) Open the Storage Bin Door, and remove all the ice to avoid contaminating by the cleaner.
- 3) Remove the Front and Top Panels.
- 4) If the icemaker is in a defrost cycle, wait until a freeze cycle starts.
- 5) Close the water supply tap.
- 6) Remove the screw, and move the Tank Drain Pipe to the drain position. See Fig. 1.

- 7) Push the Reset Switch to open the Water Pan.
- 8) Unplug the icemaker or disconnect the power source when the Water Pan has fully opened.
- 9) After the water has completely drained out, plug in the icemaker or connect the power source. When the 7-Segment Display on the Controller Board turns on, press SW1 on the Controller Board for 3 seconds to start the flush mode. (See the Controller Board Service Manual for further details.)
- 10) When the flush mode has started, pour the cleaning solution prepared in 1) carefully into the Water Tank within 60 seconds before the Pump Motor starts. Do not splash or spill the solution onto the other parts.
- 11) Circulate the cleaning solution for 30 minutes. Push the Reset Switch to open the Water Pan. Unplug the icemaker or disconnect the power source when the Water Pan has fully opened. Wait until the cleaning solution has completely drained out.
- 12) Open the water supply tap, and repeat the above step 9). Since the water supply tap is open this time, water is supplied as in the normal freeze cycle.
- 13) When the Water Pan closes again, pour clean water into the Water Pan until it floods from the Overflow Pipe, and circulate the water for 5 minutes.
- 14) Push the Reset Switch to open the Water Pan and drain the water. This time the water does not drain out completely.
- 15) Repeat the above steps 13) and 14) at least three times to rinse thoroughly. To drain the rinse water completely, unplug the icemaker or disconnect the power source when the Water Pan has fully opened.

SANITIZING INSTRUCTIONS

Note: Sanitizing should always be completed after cleaning or alternately as an individual procedure if conditions exist to make it necessary.

- 16) Use a suitable container to dilute 44 ml of 5.25% sodium hypochlorite solution with 11.4 lit. of water.

* Alternatively use the Hoshizaki recommended sanitizer as directed by the relevant instructions.

- 17) Close the water supply tap. Plug in the icemaker or connect the power source. When the 7-Segment Display on the Controller Board turns on, press SW1 on the Controller Board for 3 seconds to start the flush mode.

- 18) When the flush mode has started, pour the cleaning solution prepared in 16) carefully into the Water Tank within 60 seconds before the Pump Motor starts. Do not splash or spill the solution onto the other parts.
- 19) Circulate the sanitizing solution for 15 minutes. Push the Reset Switch to open the Water Pan. Unplug the icemaker or disconnect the power source when the Water Pan has fully opened. Wait until the sanitizing solution has completely drained out.
- 20) Open the water supply tap, and repeat the above step 9). Since the water supply tap is open this time, water is supplied as in the normal freeze cycle.
- 21) When the Water Pan closes again, pour clean water into the Water Pan until it floods from the Overflow Pipe, and circulate the water for 5 minutes.
- 22) Push the Reset Switch to open the Water Pan and drain the water. This time the water does not drain out completely.
- 23) Repeat the above steps 21) and 22) at least three times to rinse thoroughly. To drain the rinse water completely, unplug the icemaker or disconnect the power source when the Water Pan has fully opened.
- 24) Move the Tank Drain Pipe to the normal position, and secure it with the screw. See Fig. 1.
- 25) Plug in the icemaker or connect the power source. Check for proper icemaking operation.
- 26) Replace the Front Panel and Top Panel in their correct positions.
- 27) Complete Storage Bin cleaning as detailed in IV. 1. [3].

V. TECHNICAL INFORMATION

1. WATER CIRCUIT AND REFRIGERANT CIRCUIT

[a] IM-240DNE/XNE, IM-240DNE-C/XNE-C (Air-cooled)

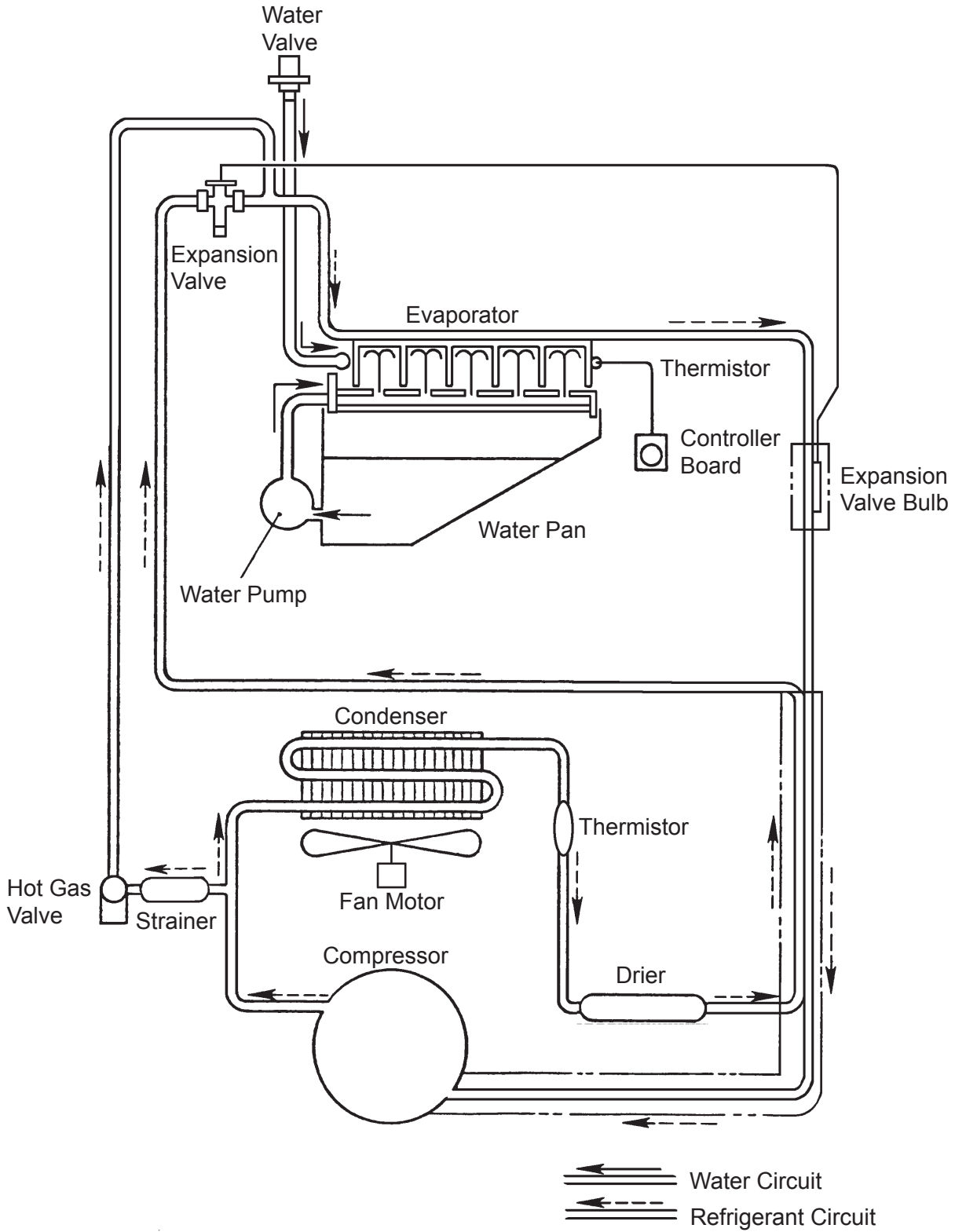

[b] IM-240DWNE/XWNE, IM-240DWNE-C/XWNE-C (Water-cooled)

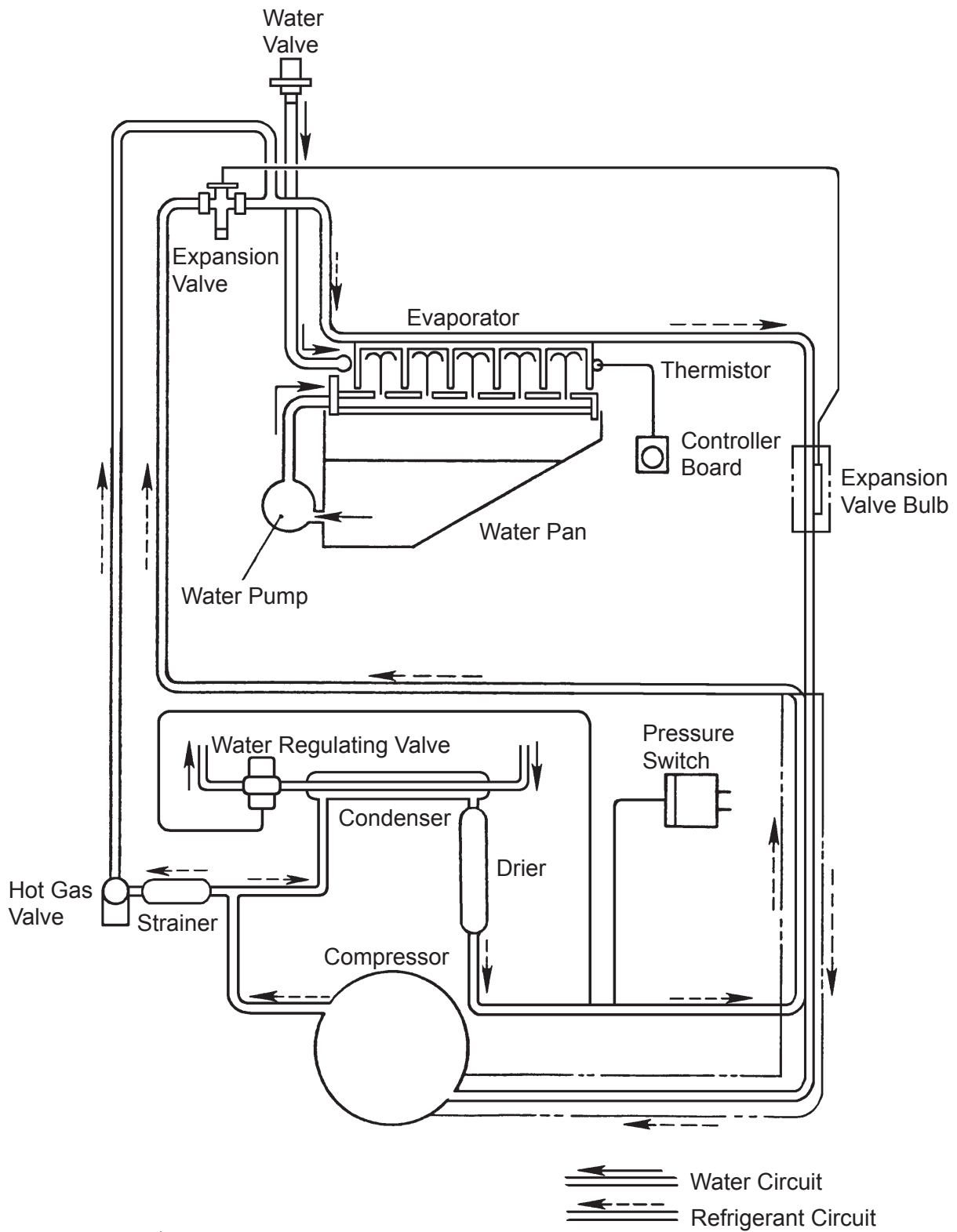

3. PERFORMANCE DATA

(Ice Production = Capacity when shipped from factory)

(*Values for icemaking water only. Use a cooling tower for cooling water.)

Model	Ambient Temp. (°C)	10	21	32	38
	Water Temp. (°C)	10	15	21	32
IM-240DNE IM-240XNE	Ice Production (kg/d)	230	220	200	170
	Freeze Cycle Time (min)	16	18.2	21.2	25.4
	Defrost Cycle Time (min)	4	2.7	1.8	1.7
	Water Consumption (lit/h)	31.3	15.7	14.2	12.1
	Electric Consumption (W)	1120	1200	1330	1450
	Head Pressure [peak] (bar)	14	17	21	25
IM-240DNE-C IM-240XNE-C	Ice Production (kg/d)	210	190	170	150
	Freeze Cycle Time (min)	18.4	22.5	25.8	29.8
	Defrost Cycle Time (min)	4.2	2.5	2.2	1.9
	Water Consumption (lit/h)	27.8	13.1	11.7	10.4
	Electric Consumption (W)	1120	1200	1330	1450
	Head Pressure [peak] (bar)	14	17	21	25
IM-240DWNE IM-240XWNE	Ice Production (kg/d)	225	202	196	185
	Freeze Cycle Time (min)	18.3	20.6	21.7	23.1
	Defrost Cycle Time (min)	2.2	2.2	1.8	1.8
	Water Consumption (lit/h)	30.7	14.4	14	13.2
	Electric Consumption (W)	1250	1260	1300	1330
	Head Pressure [peak] (bar)	19.5	19.7	19.8	20
IM-240DWNE-C IM-240XWNE-C	Ice Production (kg/d)	200	190	180	170
	Freeze Cycle Time (min)	21.6	23	24.1	26.1
	Defrost Cycle Time (min)	2.2	2	2.3	1.9
	Water Consumption (lit/h)	26.4	13.1	12.4	11.7
	Electric Consumption (W)	1250	1260	1300	1330
	Head Pressure [peak] (bar)	19.5	19.7	19.8	20

Suction Pressure and Evaporator Temp.

50/60Hz

MODEL	Ambient Temp. (°C)	10	21	32	38
	Water Temp. (°C)	10	15	21	32
IM-240 "N" type	Suction Pressure Peak (bar)	3	3.5	4	5
	Evaporator Inlet Temp. (°C)	-20	-19	-18	-17

Note: The above data are only for reference in servicing. Actual readings may be slightly different for each product.

Suction Pressure = Peak readings in freezing cycle

Evaporator Inlet Temp. = 5 minutes before completion of freezing cycle

VI. SERVICE DIAGNOSIS

1. ERROR CODE INDICATION

* See the Controller Board Service Manual for detailed diagnosis and remedies.

* The error and caution codes other than E1 and E2 are indicated as “EE” in the 7-segment display at the time of occurrence. But the error history is recorded as the actual error codes in parenthesis, and a maximum of five errors are indicated from the latest entry.

Error	Item	Description	Operation	Reset
E1	Freeze error	Freeze backup timer (45/60 minutes) counts up before freeze cycle completes, and evaporator temperature is 0°C or higher.	Shut down	Press reset switch
E2	Defrost error	Defrost backup timer (30 minutes) counts up before defrost cycle completes.	Shut down	Press reset switch
EE (E3)	Water pan opening error	Water pan has not fully opened within 60 seconds, and 3 minutes have passed even with opening failure control.	Halt	Press reset switch
		Unit resumes operation after 60 minutes and repeats the above error.	Shut down	
EE (E4)	Water pan closing error	Water pan has not fully closed within 60 seconds, and 3 minutes have passed even with closing failure control.	Halt	Press reset switch
		Unit resumes operation after 60 minutes and repeats the above error.	Shut down	
EE (E5)	High temperature error	Evaporator temperature stays 60°C or higher for 5 seconds or more.	Shut down	Press reset switch
EE (E9)	Condenser thermistor error	Condenser thermistor circuit is open or shorted for 2 seconds.	Shut down	Replace thermistor
EE (EA)	Data error	Model setting data memory IC is defective.	Shut down	Replace controller board
EE (EC)	Cube control thermistor error	Cube control thermistor circuit is open or shorted for 2 seconds.	Shut down	Replace thermistor
EE (Ed)	Water regulator error	Cooling water cannot stop by water regulator error, and thermistor senses set point or lower temperature.	Continue	Press reset switch

Caution	Item	Description	Operation	Reset
EE (C2)	High pressure	[Air-cooled] Condenser thermistor senses 63°C or higher temperature. [Water-cooled] Pressure switch senses 2.65MPa or higher pressure.	Compressor stops	After 5 minutes, condensing temperature 50°C or lower, pressure 1.96MPa or lower

2. NO ERROR CODE INDICATION

Problem	Check	Possible Cause	Remedy
Icemaker will not start.	Power source	Turned off.	Turn on.
		Supply voltage too low.	Remove cause
		Power failure	Wait until power is resumed.
	Transformer	Defective.	Replace.
	Power cord	Not connected properly.	Reconnect.
		Open circuit (damaged).	Replace.
	Controller board	Defective.	Replace.
	Fuse	Blown out.	Check for cause. Replace.
	Bin control switch	Stuck on other parts (e.g. ice guide).	Remove ice.
Short circuit (display shows "on").		Replace.	
Slab does not break into separate cubes.	Extension spring	Over-extended.	Replace.
	Water plate	Obstacle caught between evaporator and water plate.	Remove obstacle.
Icemaker will not stop when bin is filled with ice.	Bin control switch actuator	Out of position.	Place in position.
		Broken.	Replace.
	Bin control switch	Out of position.	Place in position.
		Broken.	Replace.
	Bin control switch detector	Out of position.	Place in position.
		Broken.	Replace.
	Bin control micro switch	Disconnected from switch box.	Reconnect.
Seizing with open contacts.		Replace.	
Controller board	Defective.	Replace.	
Cloudy cubes.	Water quality	High hardness.	Set hard water control.
			Switch to undiluted drain.
	Ice condition	Slush ice.	Set slush ice control.
Abnormal noise	Pump motor	Bearing worn out.	Replace.
		Vapor lock.	Clean water valve filter.
			Check water supply cycle time setting.
	Fan motor	Bearing worn out.	Replace.
		Fan touching obstacle.	Remove obstacle.
Actuator motor	Gear worn out.	Replace.	
Cubes drop separately.	Refrigeration circuit	Gas leaks (long defrost cycle).	Repair.
	Cam arm	Worn out.	Replace.

Problem	Check	Possible Cause	Remedy
Imperfect ice production.	Insufficient water supply	Water valve filter clogged.	Clean.
		Water supply cycle too short.	Extend.
		Water supply pressure too low.	Remove cause.
	Water leaks from water tank or water plate	Water tank broken.	Replace.
		Water plate broken.	Replace.
		Icemaker not level.	Adjust.
	Water valve	Water leaks valve body.	Replace.
		Water leaks from water supply pipe joint.	Check hose clamp. Replace connection hose.
	Water plate	Spray holes clogged.	Unclog.
Pump motor	Defective.	Replace.	
Large-hole cubes.	Refrigeration circuit	Gas leaks (low refrigeration capacity).	Repair.
	Condenser	Not clean (low condensing capacity).	Clean.
		Filter clogged.	Clean.
	Fan motor	Defective.	Replace.
	Installation site	No clearance at right side and rear (air-cooled model only).	Ensure clearance.
		Ambient temperature above 40°C.	Ensure ventilation to lower temperature.
	Power supply	Supply voltage too low (low refrigeration capacity).	Remove cause.
	Water valve	Water leaks.	Replace.
Insufficient water supply	Water supply pressure too low.	Remove cause.	
Freeze cycle time is too long.	Installation site	Ambient temperature too high.	Ensure ventilation to lower temperature.
	Condenser	Not clean (low condensing capacity).	Clean.
		Filter clogged.	Clean.
	Fan motor	Defective.	Replace.
Refrigeration circuit	Gas leaks ((low refrigeration capacity).	Repair.	

VII. ADJUSTMENT

1. EXPANSION VALVE

The Expansion Valve is factory-adjusted. Do not adjust it except at replacement or service. Adjust the valve setting, if necessary, as follows:

- 1) Remove the Cap Nut.
- 2) Rotate the Adjust Screw by using a flat blade screwdriver.
- 3) Watch holes of ice cubes produced. Standard setting is that Evaporator inlet side and outlet side cubes have almost the same diameters. To make the inlet side larger, rotate 90 - 180° clockwise. Smaller, counterclockwise. Do not rotate more than 180° at a time.

CAUTION

Over adjustment of the valve may result in liquid refrigerant return causing freezing to the suction line and severe damage to the Compressor.

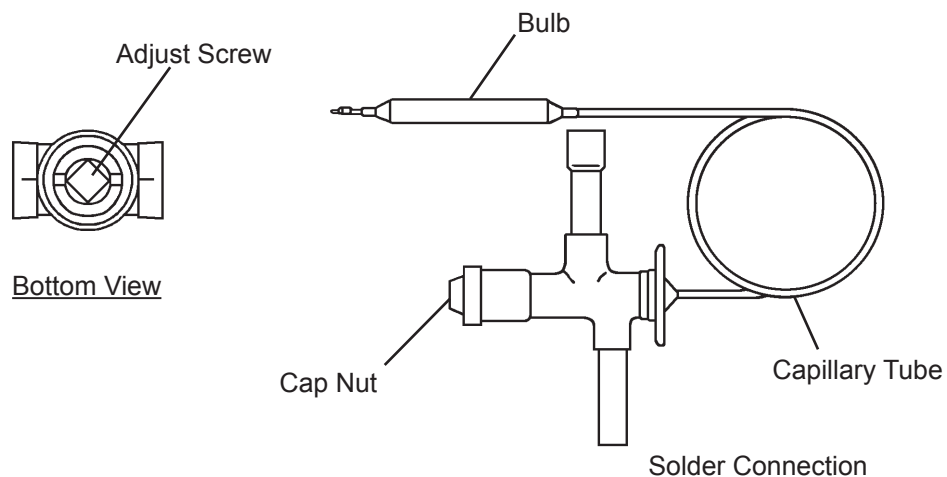

Fig. 8

2. WATER REGULATING VALVE - WATER-COOLED MODEL ONLY

The Water Regulating Valve is factory-adjusted. Do not adjust it except at replacement or service. Adjust the valve setting, if necessary, as follows:

- 1) Attach a pressure gauge to high-side line, or prepare a thermometer to check Condenser drain temperature.
- 2) Rotate the Adjust Screw using a flat blade screwdriver so that the pressure gauge shows 19 bar, or the thermometer reads 45 - 50°C, 5 minutes after Freeze Cycle starts.
When the pressure or temperature exceeds the above, rotate the Adjust Screw counterclockwise.
- 3) Check that the pressure or temperature holds.

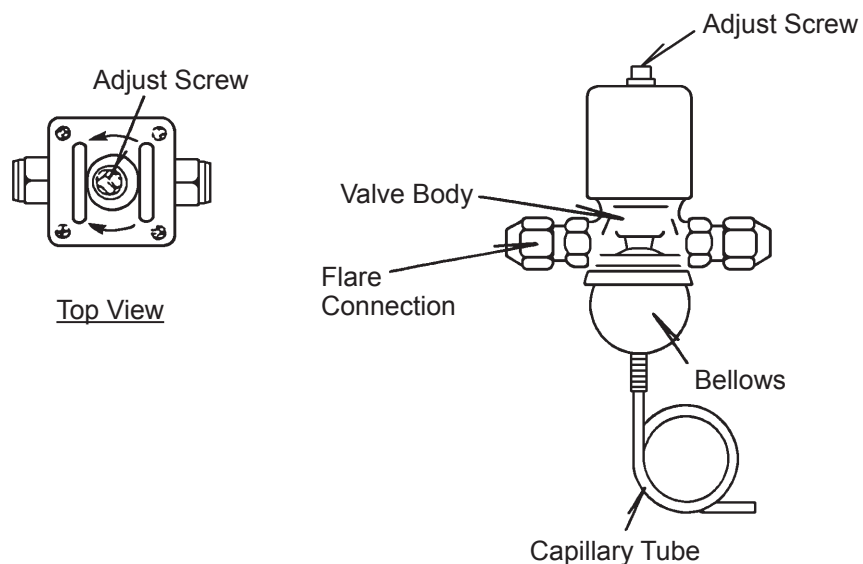

Fig. 9

VIII. REMOVAL AND REPLACEMENT

1. SERVICE FOR REFRIGERANT LINES

[a] SERVICE INFORMATION

1) Allowable Compressor Opening Time and Prevention of Lubricant Mixture [R404A]

The compressor must not be opened more than 30 minutes in replacement or service. Do not mix lubricants of different compressors even if both are charged with the same refrigerant, except when they use the same lubricant.

2) Treatment for Refrigerant Leak [R404A]

If a refrigerant leak occurs in the low side of an ice maker, air may be drawn in. Even if the low side pressure is higher than the atmospheric pressure in normal operation, a continuous refrigerant leak will eventually reduce the low side pressure below the atmospheric pressure and will cause air suction. Air contains a large amount of moisture, and ester oil easily absorbs a lot of moisture. If an ice maker charged with R404A has possibly drawn in air, the drier must be replaced. Be sure to use a drier designed for R404A.

3) Handling of Handy Flux [R404A]

Repair of the refrigerant circuit needs brazing. It is no problem to use the same handy flux that has been used for the current refrigerants. However, its entrance into the refrigerant circuit should be avoided as much as possible.

4) Oil for Processing of Copper Tubing [R404A]

When processing the copper tubing for service, wipe off oil, if any used, by using alcohol or the like. Do not use too much oil or let it into the tubing, as wax contained in the oil will clog the capillary tubing.

5) Service Parts for R404A

Some parts used for refrigerants other than R404A are similar to those for R404A. But never use any parts unless they are specified for R404A because their endurance against the refrigerant has not been evaluated. Also, for R404A, do not use any parts that have been used for other refrigerants. Otherwise, wax and chlorine remaining on the parts may adversely affect the R404A.

6) Replacement Copper Tubing [R404A]

The copper tubes currently in use are suitable for R404A. But do not use them if oily inside. The residual oil in copper tubes should be as little as possible. (Low residual oil

type copper tubes are used in the shipped units.)

7) Evacuation, Vacuum Pump and Refrigerant Charge [R404A]

Never allow the oil in the vacuum pump to flow backward. The vacuum level and vacuum pump may be the same as those for the current refrigerants. However, the rubber hose and gauge manifold to be used for evacuation and refrigerant charge should be exclusively for R404A.

8) Refrigerant Leak Check

Refrigerant leaks can be detected by charging the unit with a little refrigerant, raising the pressure with nitrogen and using an electronic detector. Do not use air or oxygen instead of nitrogen for this purpose, or rise in pressure as well as in temperature may cause R404A to suddenly react with oxygen and explode. Be sure to use nitrogen to prevent explosion.

[b] REFRIGERANT RECOVERY

The refrigerant must be recovered if required by an applicable law. A Low-side Access Valve is provided on an extension pipe connected to the suction port of the Compressor. On the DNE/XNE(-C) and DWNE/XWNE(-C), a Tap Valve should initially be fitted to the High-side Process Tube to be replaced with a proper Access Valve (see Fig. 10) when recovery is completed.

[c] EVACUATION AND RECHARGE

- 1) On the DNE/XNE(-C) and DWNE/XWNE(-C), attach Charging Hoses, Service Manifold and Vacuum Pump to the Low-side and High-side (to be fitted by servicer) Access Valves.
- 2) Turn on the Vacuum Pump.
- 3) Allow the Vacuum Pump to pull down to a 760 mmHg vacuum. Evacuating period depends on the pump capacity.
- 4) Close the Low-side and High-side Valves on the Service Manifold.
- 5) Disconnect the Vacuum Pump, and attach a Refrigerant Charging Cylinder to accurately weigh in the liquid charge. Remember to purge any air from the Charging Hose. See the Nameplate for the required refrigerant charge.
- 6) Open the High-side Valve on the Gauge Manifold, and accurately measure in the liquid charge. Close the valve on the Charging Cylinder before closing the High-side Manifold Valve. Any remaining liquid in the line can be charged into the low side.

Note: Always charge in the liquid stage, as many refrigerants are blends and vapour charging will affect the blend consistency (eg. R404A).

- 7) Turn on the icemaker. Release the High-side Access Connector, and allow pressure in the charging line to slowly enter the low side of the system. Cap off the High-side Access Valve. When pressure reduces on the low side, disconnect the low side charging line and cap off the Access Valve.
- 8) Always cap the Access Valves to prevent a refrigerant leak.
- 9) Always thoroughly leak test all joints and valve caps.
- 10) Avoid charging large quantities of liquid into the low side in case of damage to the Compressor.

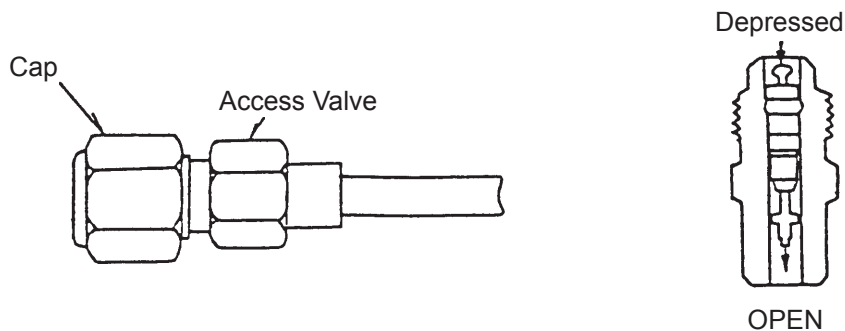

Fig. 10

2. COMPRESSOR

- 1) Unplug the icemaker or disconnect the power source.
- 2) Remove the Top, Front and Right Side Panels.
- 3) Recover the refrigerant and store it in a proper container, if required by an applicable law (See "1. [b] REFRIGERANT RECOVERY").
- 4) Remove the Terminal Cover on the Compressor, and disconnect Solderless Terminals.
- 5) Disconnect the Discharge and Suction Pipes using brazing equipment.
- 6) Remove the Hold-down Bolts, Washers and Rubber Grommets.
- 7) Slide and remove the Compressor. Unpack the new Compressor package.
- 8) Attach the Rubber Grommets of the previous Compressor.
- 9) Clean the Suction and Discharge Pipes with an abrasive cloth/paper.

- 10) Place the Compressor in position, and secure it using the Bolts and Washers.
- 11) Remove Plugs from the Compressor Suction and Discharge Pipes.
- 12) Braze or solder the Access, Suction and Discharge lines (Do not change this order), with nitrogen gas flowing at the pressure of 0.2 - 0.3 bar.
- 13) Install the new Drier (See "3. DRIER").
- 14) Check for leaks using nitrogen gas (10 bar) and soap bubbles.
- 15) Evacuate the system and charge it with refrigerant (See "1. [c] EVACUATION AND RECHARGE").
- 16) Connect the Solderless Terminals and replace the Terminal Cover in its correct position.
- 17) Replace the panels in their correct positions.
- 18) Plug in the icemaker or connect the power source.

Note: Hoshizaki recommends that Compressor starting electrics are always replaced at the same time as the Compressor.

3. DRIER

- 1) Unplug the icemaker or disconnect the power source.
- 2) Remove the Top, Front and Right Side Panels.
- 3) Recover the refrigerant and store it in a proper container, if required by an applicable law (See "1. [b] REFRIGERANT RECOVERY").
- 4) Remove the Drier Holder, if any, and pull the Drier toward you for easy service.
- 5) Remove the Drier using brazing equipment.
- 6) Braze or solder the new Drier, with the arrow on the Drier in the direction of the refrigerant flow. Use nitrogen gas at the pressure of 0.2 - 0.3 bar when brazing tubings.
- 7) Check for leaks using nitrogen gas (10 bar) and soap bubbles.
- 8) Evacuate the system and charge it with refrigerant (See "1. [c] EVACUATION AND RECHARGE").

9) Replace the panels in their correct positions.

10) Plug in the icemaker or connect the power source.

Note: Always use a Drier of the correct capacity and refrigerant type.

4. EXPANSION VALVE

IMPORTANT

Always install a new Drier every time the sealed refrigeration system is opened. Do not replace the Drier until after all other repair or replacement has been made.

- 1) Unplug the icemaker or disconnect the power source.
- 2) Remove the Top, Front and Right Side Panels.
- 3) Recover the refrigerant and store it in a proper container, if required by an applicable law (See "1. [b] REFRIGERANT RECOVERY").
- 4) Remove the Expansion Valve using brazing equipment. Protect the Evaporator and pipes from excessive heat with damp cloths or similar.
- 5) Remove the Expansion Valve Sensor (Bulb).
- 6) Remove the Drier using brazing equipment.
- 7) Braze in the new Expansion Valve. Protect the body of the valve from excessive heat, and use nitrogen at a pressure of 0.2 - 0.3 bar when brazing.
- 8) Braze or solder the new Drier (See "3. DRIER").
- 9) Check for leaks using nitrogen gas (10 bar) and soap bubbles.
- 10) Evacuate the system and charge it with refrigerant (See "1. [c] EVACUATION AND RECHARGE").
- 11) Attach the Bulb to the suction line in position. Be sure to secure it using a wire or clamp and replace the insulation.

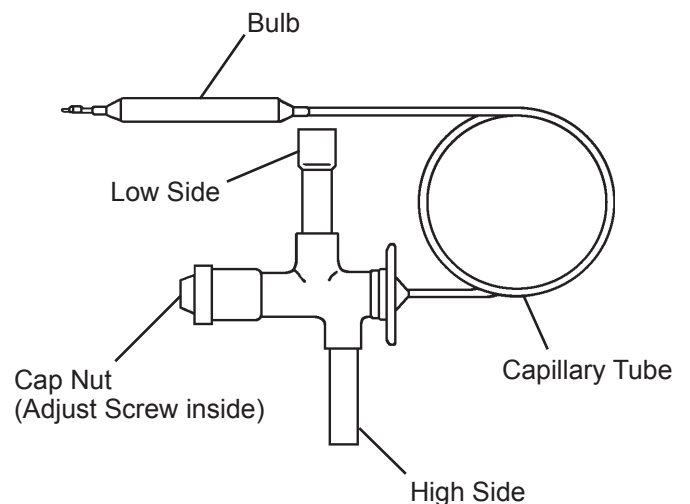

Fig. 11

- 12) Replace the panels in their correct positions.
- 13) Plug in the icemaker or connect the power source.

5. EVAPORATOR

IMPORTANT

Always install a new Drier every time the sealed refrigeration system is opened. Do not replace the Drier until after all other repair or replacement has been made.

- 1) Unplug the icemaker or disconnect the power source.
- 2) Remove the Top, Front, Right and Left Side Panels.
- 3) Recover the refrigerant and store it in a proper container, if required by an applicable law (See “1. [b] REFRIGERANT RECOVERY”).
- 4) Remove the Water Pan Assembly, referring to “8. WATER PAN ASSEMBLY”.
- 5) Disconnect the solder connections on the Evaporator using brazing equipment. Protect the Expansion Valve from excessive heat.
- 6) Remove four nuts holding the Evaporator.
- 7) Install the new Evaporator, and secure it with the Bolts, Collars (Spacer) and Nuts.
- 8) Install the new Drier (See “3. DRIER”).
- 9) Braze pipes, with nitrogen gas flowing at the pressure of 0.2 - 0.3 bar.
- 10) Check for leaks using nitrogen gas (10 bar) and soap bubbles.
- 11) Evacuate the system and charge it with refrigerant (See “1. [c] EVACUATION AND RECHARGE”).
- 12) Replace the removed panels in their correct positions.
- 13) Plug in the icemaker or connect the power source.

6. HOT GAS VALVE

IMPORTANT

Always install a new Drier every time the sealed refrigeration system is opened. Do not replace the Drier until after all other repair or replacement has been made.

- 1) Unplug the icemaker or disconnect the power source.
- 2) Remove the Top, Front and Right Side Panels.
- 3) Recover the refrigerant and store it in a proper container, if required by an applicable law (See "1. [b] REFRIGERANT RECOVERY").
- 4) Disconnect the Hot Gas Valve leads.
- 5) Remove the screw and the Solenoid Coil.
- 6) Remove the valve and Drier using brazing equipment.
- 7) Braze the new Hot Gas Valve with nitrogen gas flowing at the pressure of 0.2 - 0.3 bar.

WARNING

Always protect the valve body by using a damp cloth to prevent the valve from overheating. Do not braze with the valve body exceeding 120°C.

- 8) Install the new Drier (See "3. DRIER").
- 9) Check for leaks using nitrogen gas (10 bar) and soap bubbles.
- 10) Evacuate the system and charge it with refrigerant (See "1. [c] EVACUATION AND RECHARGE").
- 11) Attach the Solenoid Coil to the valve body, and secure it with the screw.
- 12) Connect the leads.
- 13) Replace the panels in their correct positions.
- 14) Plug in the icemaker or connect the power source.

7. WATER REGULATING VALVE - WATER-COOLED MODEL ONLY

[a] VALVE BODY

- 1) Unplug the icemaker or disconnect the power source.
- 2) Close the water supply tap.
- 3) Remove the Front Panel and Right Side Panel.
- 4) Disconnect the flare connections of the Water Regulating Valve.
- 5) Remove the valve from the Bracket.
- 6) Install a new Water Regulating Valve.
- 7) Connect the flare connections.
- 8) Open the water supply tap.
- 9) Check for water leaks.
- 10) Replace the panels in their correct positions.
- 11) Plug in the icemaker or connect the power source.

[b] WHOLE VALVE

IMPORTANT

Always install a new Drier every time the sealed refrigeration system is opened. Do not replace the Drier until after all other repair or replacement has been made.

- 1) Unplug the icemaker or disconnect the power source.
- 2) Close the water supply tap.
- 3) Remove the Front, Top and Right Side Panels.
- 4) Recover the refrigerant and store it in a proper container, if required by an applicable law (See "1. [b] REFRIGERANT RECOVERY").
- 5) Cut off the Copper Tube near the Capillary Tube solder connection, using a pipe cutter.

- 6) Cut off the Capillary Tubes of the Valve and High-pressure Switch, using a file and pliers. Be careful not to damage the Capillary Tube end.
- 7) Disconnect the flare connections from the Bracket.
- 8) Remove the screws and the valve from the Bracket.
- 9) Install the new valve, and insert the Capillary Tubes into the Copper Tube.
- 10) Web the Copper Tube end, and braze or solder the Copper Tube and Capillary Tubes together.
- 11) Install the new Drier (See “3. DRIER”).
- 12) Check for leaks using nitrogen gas (10 bar) and soap bubbles.
- 13) Evacuate the system and charge it with refrigerant (See “1. [c] EVACUATION AND RECHARGE”).
- 14) Connect the flare connections.
- 15) Open the water supply tap.
- 16) Check for water leaks.
- 17) Replace the panels in their correct positions.
- 18) Plug in the icemaker or connect the power source.

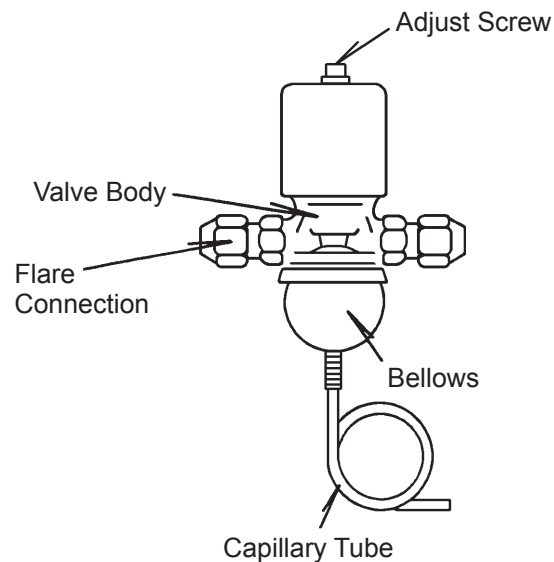
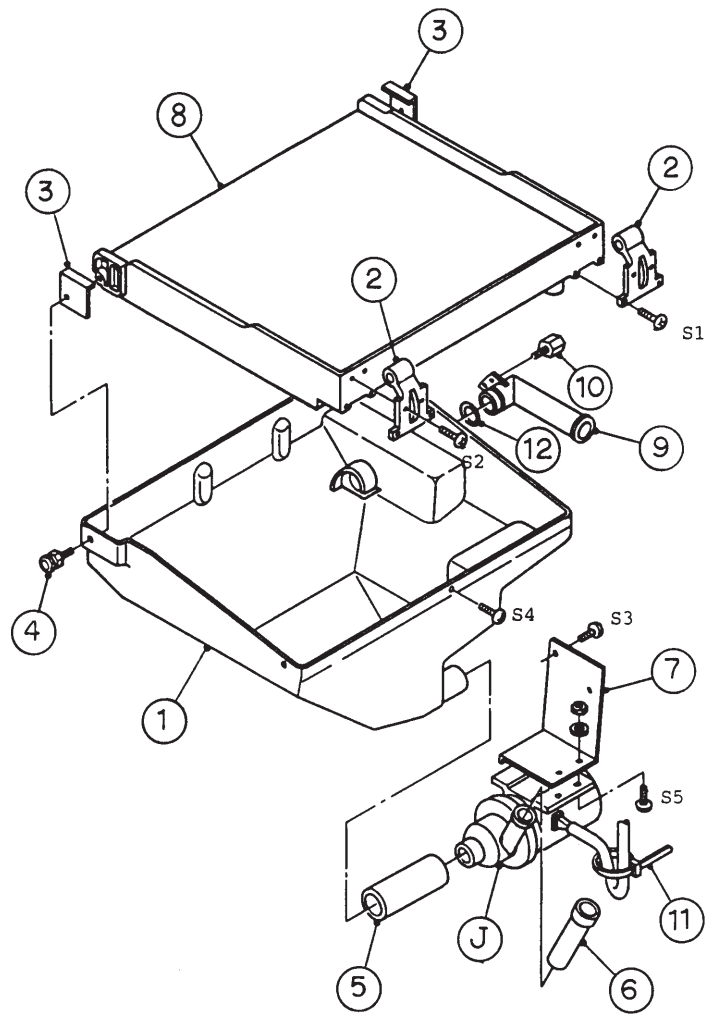

Fig. 12

8. WATER PAN ASSEMBLY

- 1) Remove the Top, Front and Left Side Panels.
- 2) Push the Reset Switch on the Control Box to open the Water Pan.
- 3) Unplug the icemaker or disconnect the power source.
- 4) Disconnect the Pump Motor leads in the Wiring Channel.
- 5) Remove the two Extension Springs from the Cam Arms.
- 6) Remove the Water Plate Bracket and the Water Pan Assembly.
- 7) Remove the two Spring Hook Screws from the Water Tank.
- 8) Remove the screws and the Water Plate Bracket.
- 9) Remove the Pump Suction and Discharge Tubings.
- 10) Remove the Pump Motor Bracket from the Water Plate.
- 11) Install the new Water Plate or Water Tank in the reverse order of the removal procedure.
- 12) Replace the panels in their correct positions.
- 13) Plug in the icemaker or connect the power source.



INDEX NO.	DESCRIPTION
1	Water Tank
2	Water Plate Bracket
3	Bracket
4	Spring Hook Screw
5	Pump Tubing (Suction)
6	Pump Tubing (Discharge)
7	Pump Motor Bracket
8	Water Plate
9	Overflow Pipe
10	Thumbscrew (for Overflow Pipe)
11	Nylon Tie
12	O-ring
J	Pump Motor Assembly
S1 - 4	Tapping Screw
S5	Machine Screw

Fig. 13

9. PUMP MOTOR

- 1) Unplug the icemaker or disconnect the power source.
- 2) Remove the Top Panel and Front Panel.
- 3) Disconnect the Pump Motor leads in the Wiring Channel.
- 4) Unscrew and remove the Pump Motor from the Bracket.
- 5) Disconnect the Pump Suction and Discharge Tubings.
- 6) Install the new motor in the reverse order of the removal procedure.
- 7) Plug in the icemaker or connect the power source, and check for leaks.
- 8) Replace the panels in their correct positions.

10. WATER VALVE

- 1) Close the water supply tap.
- 2) Unplug the icemaker or disconnect the power source.
- 3) Remove the Top Panel and Front Panel.
- 4) Disconnect the Receptacle (leads) from the Water Valve.
- 5) Remove the Valve Outlet tubing by releasing the Clamp.
- 6) Remove the Inlet Hose and Water Valve.
- 7) Install the new valve in the reverse order of the removal procedure.
- 8) Open the water supply tap.
- 9) Plug in the icemaker or connect the power source.
- 10) Check for leaks.
- 11) Replace the panels in their correct positions.

Note: When replacing parts, disassemble as shown in Fig. 6 and replace the defective parts.

11. ACTUATOR MOTOR

- 1) Remove the Top Panel and Front Panel.
- 2) Push the Reset Switch on the Control Box to open the Water Pan.
- 3) Unplug the icemaker or disconnect the power source.
- 4) Remove the Extension Spring (Actuator Motor side) from the Cam Arm.
- 5) Disconnect the Actuator Motor leads in the Wiring Channel.
- 6) Remove the Actuator Motor Bracket.
- 7) Remove the Spring Pin securing the Shaft to the Cam Arm.
- 8) Remove the Actuator Motor.
- 9) Install the new Actuator Motor in the reverse order of the removal procedure.
- 10) Check that the Cam Arm can move in the proper range.
- 11) Replace the panels in their correct positions.
- 12) Plug in the icemaker or connect the power source.

12. CAM ARM

[a] CAM ARM (A) - ACTUATOR MOTOR SIDE

Refer to "11. ACTUATOR MOTOR".

[b] CAM ARM (B) - REAR SIDE

- 1) Remove the Top Panel and Front Panel.
- 2) Push the Reset Switch on the Control Box to open the Water Pan.
- 3) Unplug the icemaker or disconnect the power source.
- 4) Remove the Extension Spring from the Cam Arm (B).
- 5) Remove the Split Pin from the Cam Shaft.
- 6) Remove the Cam Arm (B).

- 7) Install the new Cam in the reverse order of the removal procedure.
- 8) Replace the panels in their correct positions.
- 9) Plug in the icemaker or connect the power source.

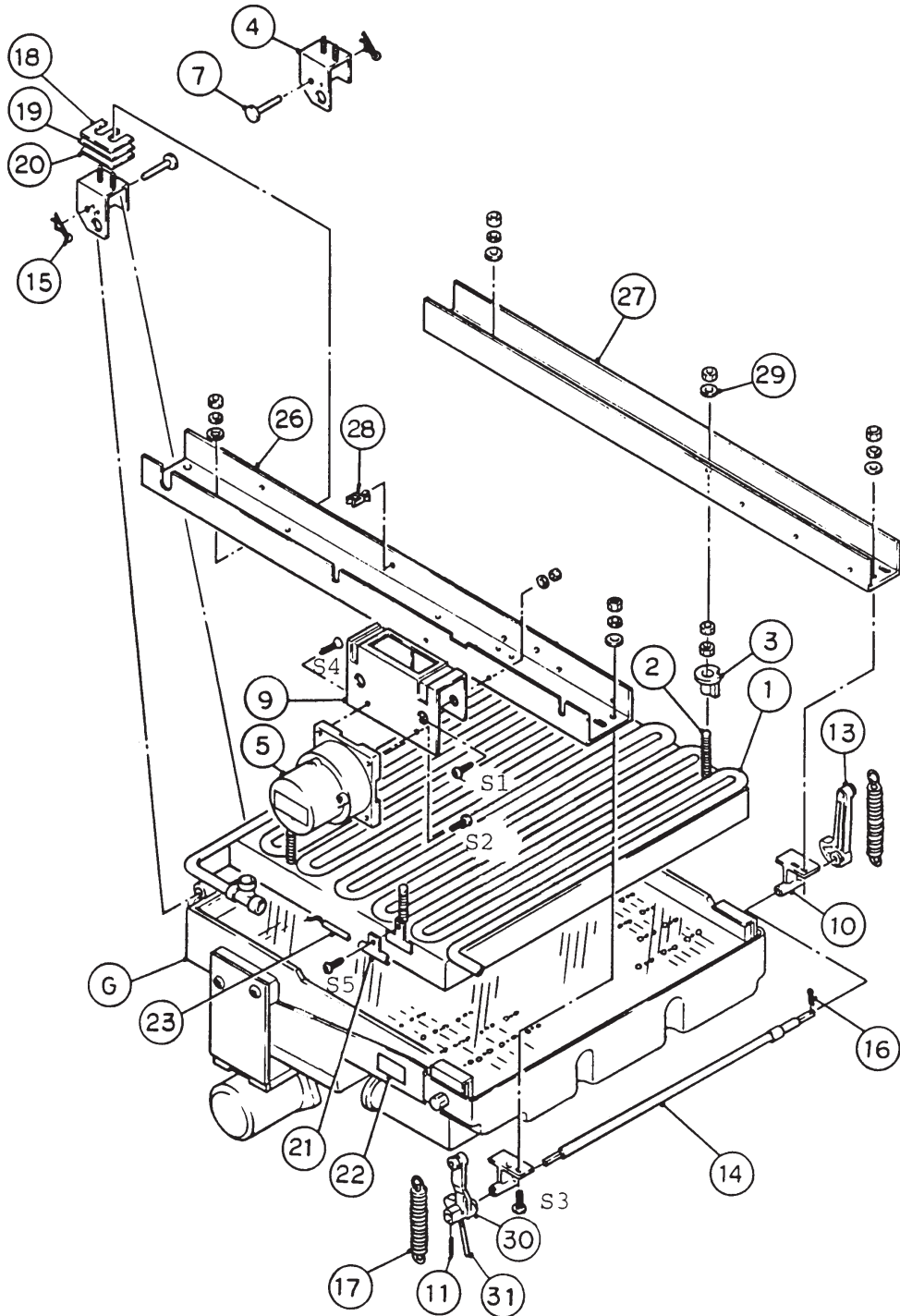

Fig. 14

ICEMAKING ASSEMBLY AND CAM MECHANISM

INDEX NO.	DESCRIPTION
G	Water Pan Assembly
1	Evaporator
2	Bolt
3	Collar (Spacer)
4	Bearing
5	Actuator Motor
7	Shaft
9	Actuator Motor Bracket
10	Cam Shaft Bearing
11	Spring Pin
13	Cam Arm (B)
14	Cam Shaft
15	Snap Pin
16	Split Pin
17	Spring
18	Washer (A)
19	Washer (B)
20	Washer (C)
21	Thermistor Holder
22	Label (for Overflow Pipe)
23	Thermistor (Cube Control)
26	Frame
27	Frame
28	Wire Saddle
29	Washer
30	Cam Arm (A)
31	Change Lever
S1 - 5	Machine Screw

13. CONTROLLER BOARD

IMPORTANT

Some adjustment will be required for the Controller Board to fit the icemaker models. Do not repair any parts and electronic devices on the Controller Board in the field. Replace the whole board with a new Service Board.

- 1) Unplug the icemaker or disconnect the power source.
- 2) Remove the Front Panel.
- 3) Unscrew and remove the Control Box Cover.
- 4) Disconnect all the Connectors from the Controller Board.
- 5) Remove the Controller Board from the four Board Supports for connection to the Control Box.
- 6) Install the new Controller Board in the reverse order of the removal procedure.
- 7) Replace the Front Panel in its correct position.
- 8) Plug in the icemaker or connect the power source.
- 9) The icemaker restarts in the model setting mode. Set the model code according to the Controller Board Service Manual.

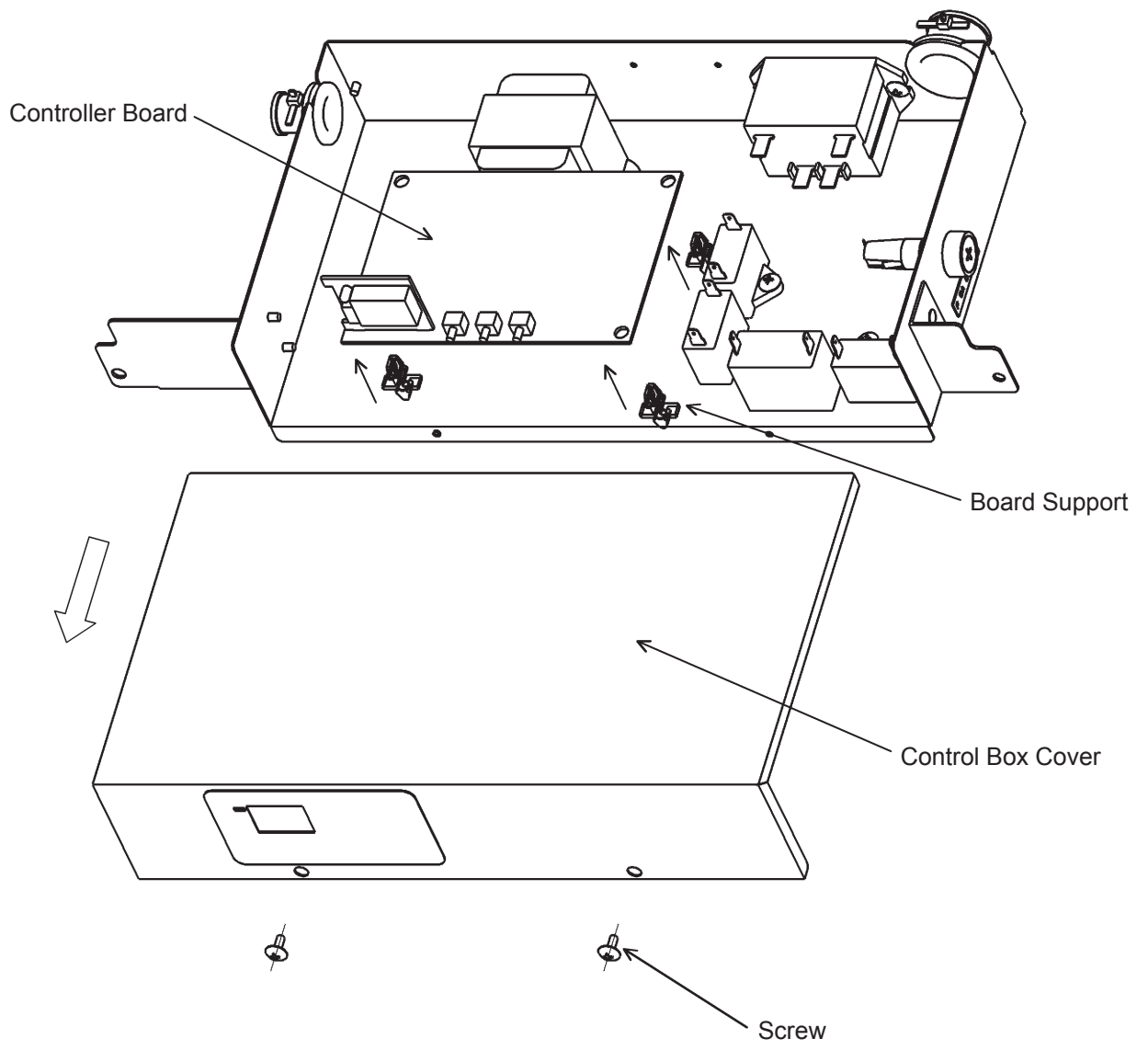
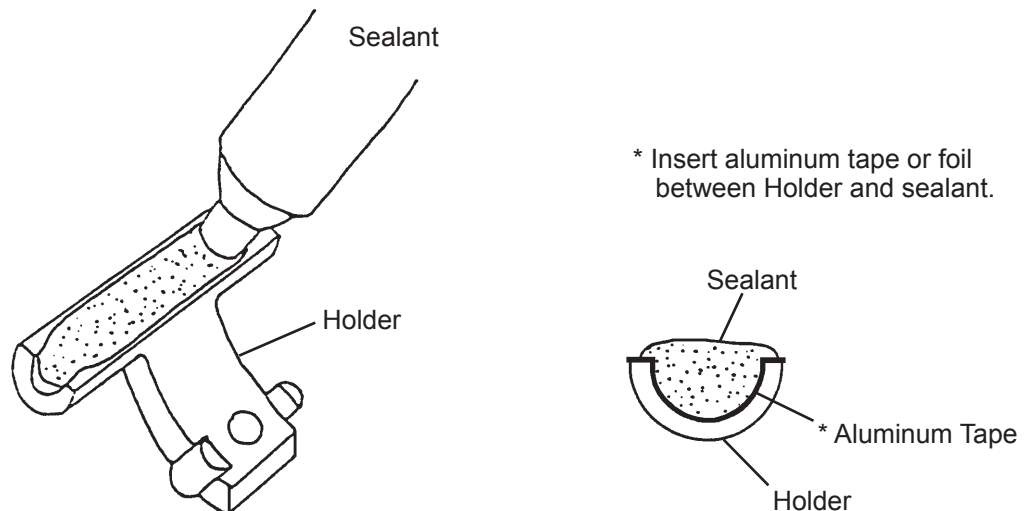

Fig. 15

14. THERMISTOR FOR CUBE CONTROL

- 1) Unplug the icemaker or disconnect the power source.
- 2) Remove the Top and Front Panels.
- 3) Remove the Connector CN13 on the Controller Board, referring to “13. CONTROLLER BOARD”.
- 4) Unscrew and remove the Thermistor Holder and Thermistor, located on the Evaporator (Front Side).
- 5) Install the new thermistor in the reverse order of the removal procedure, by using a sealant (High-thermal Conduct Type). See Fig. 16.

Note: Recommended sealant is KE4560RTV, manufactured by Shin-Etsu Silicones. When other type of sealant used, the cube size and performance will be changed. Do not use silicone sealant as this will insulate the Thermistor.



** Thermistor and Leads are FRAGILE.
HANDLE WITH CARE.

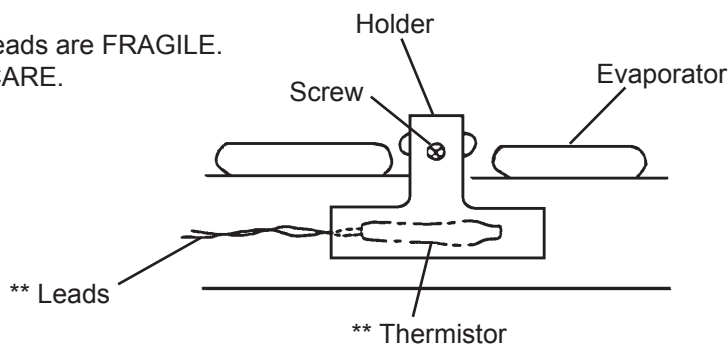

Fig. 16

15. FAN MOTOR - DNE(-C)/XNE(-C) ONLY

- 1) Unplug the icemaker or disconnect the power source.
- 2) Remove the Top, Front and Right Side Panels.
- 3) Disconnect the Connector of the Fan Motor.
- 4) Remove the Fan Motor Bracket and the Fan Motor.
- 5) Cut the leads of the Fan Motor allowing enough lead length to reconnect using closed end connectors.
- 6) Install the new Fan Motor in the reverse order of the removal procedure.
- 7) Refit the panels in their correct positions.
- 8) Plug in the icemaker or connect the power source.