



HOSHIZAKI SELF-CONTAINED CUBER

**MODEL IM-240NE
IM-240NE-21,-23
IM-240WNE,-23**

E1EC,E1EC-D001,D002,D003,D004,D020

PARTS LIST

[HE] [GRAM]

A-1	AUG.	2011
B-0	JAN.	2012
B-1	JAN.	2012
B-2	JUN.	2012
B-3	---	2012
B-4	OCT.	2012
C-0	JAN.	2013
D-0	JAN.	2014
E-0	JAN.	2015

AUXILIARY CODE

U - 1

The auxiliary code is the first two characters in the serial number. The first character indicates the production year. Years progress or regress in alphabetical order. The series of letters and skipped letters depend on UL listing, production, and model. See the auxiliary code(s) and corresponding year(s) on the front cover.

The second character indicates significant part changes within the same year. Base is "1" and this number advances for each change. If there is no significant part change at the turn of the year, this number starts from "0."

MARKS LOCATED UNDER THE AUXILIARY CODE

- = Part deleted.
- x = Part deleted and replaced by "o" part.
- o = New part in place of "x" part.

FASTENER PART NUMBER

SCREWS

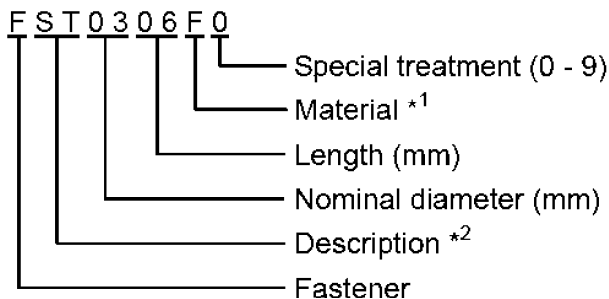

^{*1} Material

- F: Steel
- S: Austenitic stainless steel
- M: Martensitic stainless steel
- B: Copper alloy
- P: Polycarbonate
- N: Polyamide
- V: PVC
- A: ABS
- X: Polyacetal
- L: Aluminum

NUTS & WASHERS

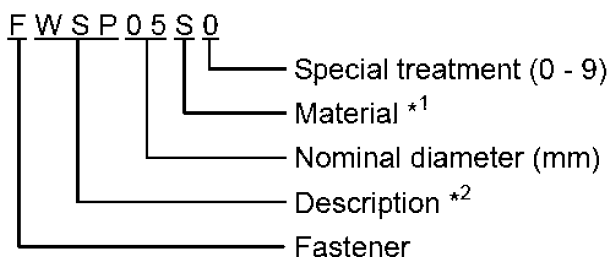

^{*2} Description

- First letter
- S: Machine screw
- T: Tapping screw
- M: Wood screw
- B: Bolt
- W: Washer
- N: Nut

IM-240NE(-21, -23)
IM-240WNE(-23)

A. ICE CUBBER ASSY (1/2) (A-1) and later

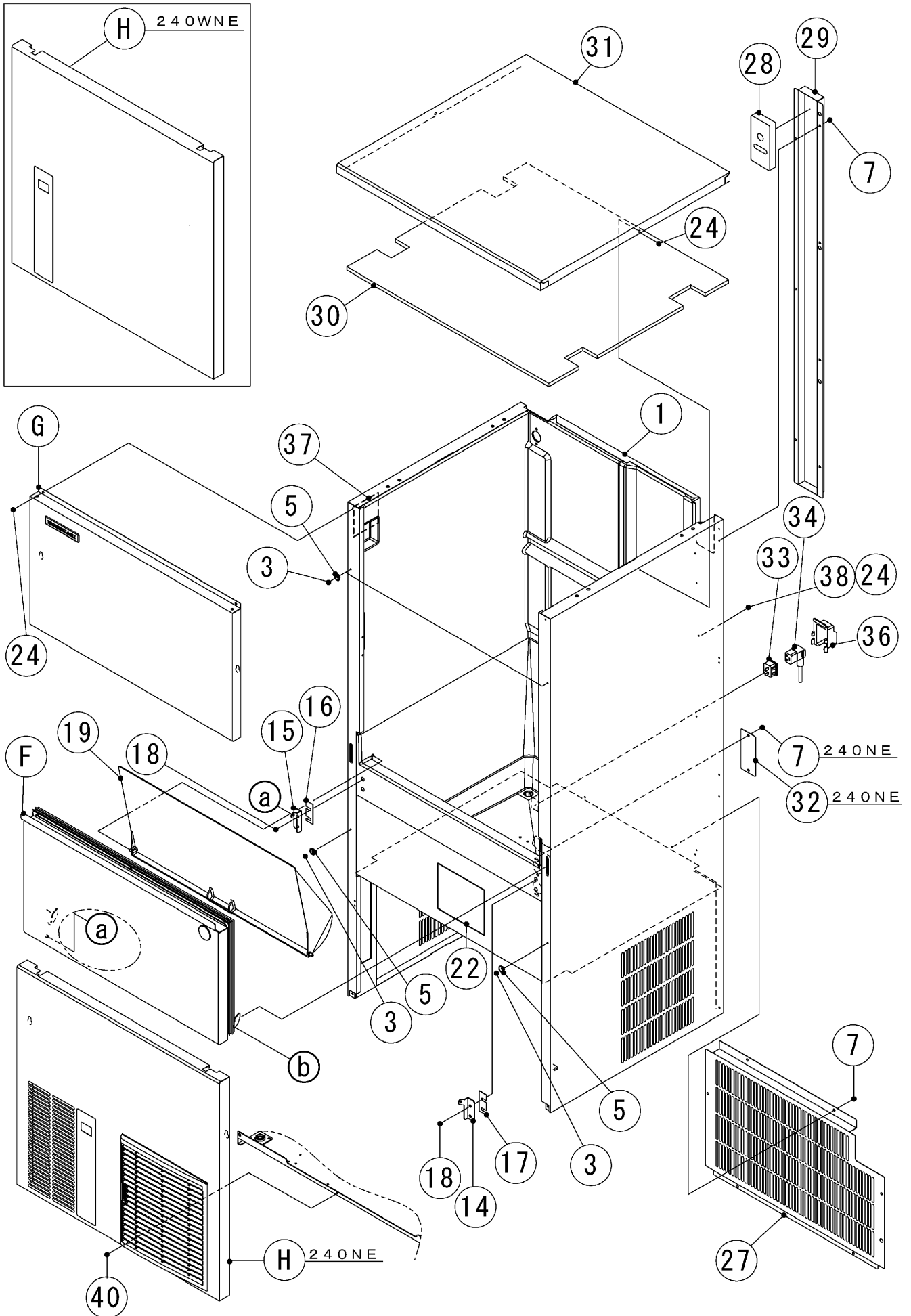

IM-240NE(-21,-23)
IM-240WNE(-23)

A. ICE CUBBER ASSY (2/2) (A-1) and later

IM-240WNE

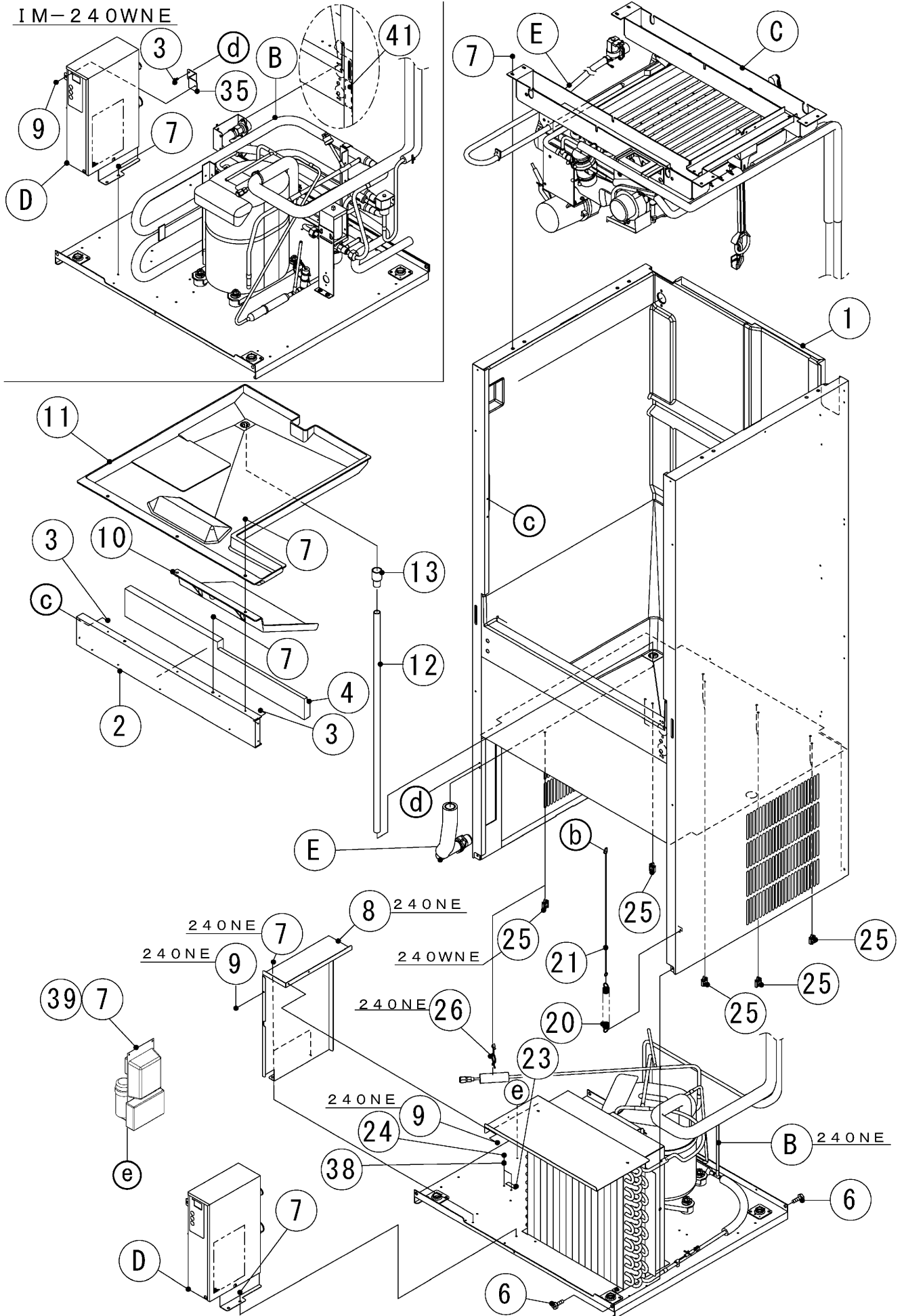

HE,GRAM

MODEL: IM-240NE,-21,-23 IM-240WNE,-23				TITLE: A.ICE CUBBER ASSY			
INDEX NO.	DESCRIPTION	MATERIAL OR MODEL NUMBER	PART NUMBER	REQ'D NUMBER			
				A-1,B-0 B-1	B-2 B-3	B-4,C-0 D-0,E-0	
B	REFRIGERATION ASSY	(240NE,-21,-23)	1H4761A01	1	-	-	
			1H5213A01	-	1	1	
		(240WNE,-23)	1H4791A01	1	-	-	
			1H5216A01	-	1	1	
C	MECHANISM ASSY		1H4762A01	1	1	1	
D	CONTROL BOX ASSY	(240NE,-21,-23)	2X0291A01	1	-	-	
			2X1197A01	-	1	1	
		(240WNE,-23)	2X0366A01	1	-	-	
			2X1197A02	-	1	1	
E	WATER CIRCUIT ASSY		2X0293A01	1	1	1	
F	DOOR ASSY		3Y5436A01	1	1	1	
G	FRONT COVER UPPER ASSY		3Y5438A01	1	1	1	
		(GRAM)	3Y5438A02	-	-	1	
H	FRONTCOVER(LOWER) ASSY	(240NE,-21,-23)	3Y5439A01	1	-	-	
			2X1261A01	-	1	1	
		(240WNE,-23)	3Y5544A01	1	-	-	
			3Y6776A01	-	1	1	
M	ACCESSORIES			1	1	1	
1	BODY		1H4759G01	1	1	1	
2	FRONT FRAME		3X9103-01	1	1	1	
3	RIVET		7170-0002	8	8	8	
4	INSULATION - FRONT FRAME		4Y6991P01	1	1	1	
5	TAPER COLLAR		4H0171-01	4	4	4	
6	T2 SCREW	(240NE,-23)	1H4766-01	4	-	-	
		(240WNE)	1H4794-01	4	-	-	
	TAPPING SCREW - HEX		442040-01	-	4	4	
7	FLANGE BOLT (S-TITE)	(240NE,-21,-23)	FTR0408M0	32	-	-	
				-	34	34	
		(240WNE,-23)		29	-	-	
				-	32	32	
8	COVER - CONT	(240NE,-23)	2X0292M01	1	-	-	
9	TRUSS HEAD TAPPING SCREW T2	(240NE,-23)	FT20408F0	3	-	-	
		(240WNE)	FT20408F0	1	-	-	
10	ICE GUIDE G		4Y7002G01	1	1	1	
11	DRAIN PAN		3Y5434G01	1	1	1	

HE,GRAM

MODEL: IM-240NE,-21,-23 IM-240WNE,-23				TITLE: A.ICE CUBBER ASSY			
INDEX NO.	DESCRIPTION	MATERIAL OR MODEL NUMBER	PART NUMBER	REQ'D NUMBER			
				A-1,B-0 B-1	B-2 B-3	B-4,C-0 D-0,E-0	
12	DRAIN PIPE		4X7117-02	1	1	1	
13	DRAIN TUBE		4H2585-01	1	1	1	
14	HINGE (RIGHT)		4H2583-01	1	1	1	
15	HINGE (LEFT)		4H2584-01	1	1	1	
16	HINGE SPACER (A)		4H0605-01	1	1	1	
17	HINGE SPACER (B)		4H0605-02	1	1	1	
18	HEX HEAD BOLT (SPRING WASHER AND FLAT WASHER)		FBK0616S0	4	4	4	
19	SLOPE		3X4854G01	1	1	1	
20	SPRING		4H0823-01	1	1	1	
21	HOOK		4H2685-03	1	1	1	
22	WIRING LABEL		3Y5103L01	1	-	-	
			3Y6692L01		1	1	
23	LABEL - GROUND		451712-01	1	-	-	
	LABEL - GROUND (B)		450452-02	-	1	1	
24	TRUSS HEAD MACHINE SCREW	(240NE,-21,-23)	FST0408S0	7	7	7	
		(240WNE,-23)		7	8	8	
25	WIRE SADDLE	(240NE,-21,-23)	428060-03	8	8	8	
		(240WNE,-23)		9	9	9	
26	CLAMP	(240NE,-21,-23)	427902-06	1	1	1	
27	REAR PANEL		2X0296M01	1	1	1	
28	INSULATION - PIPE		4Y2507-01	1	1	1	
29	COVER - PIPE		3Y5440M01	1	1	1	
30	INSULATION - TOP PANEL		3X9100-01	1	1	1	
31	TOP PANEL		1H4765M01	1	1	1	
32	COVER - REAR	(240NE,-21,-23)	4Y7004M01	1	1	1	
33	CONNECTOR		P00246-01	1	1	1	
34	POWER SUPPLY CORD	EU-PLUG(16A)	P03362-01	1	1	1	
		UK-PLUG(13A)	P03363-01	1	1	1	
		AS-PLUG(15A)	P03364-01	1	1	1	
35	BRACKET - CONT	(240WNE)	4Y7326M01	1	-	-	
36	COVER - CONNECTOR		2X0271P01	1	1	1	
37	NAME PLATE		N/A	1	1	1	
38	SPRING WASHER		FWSP04S0	2	3	3	
39	STARTING DEVICE		P01856-01	-	1	1	
40	S-TITE TRUSS HEAD SCREW		FTS0408M0	1	1	1	
41	LABEL-CONNECTION	(240WNE,-23)	464541-01	1	1	1	

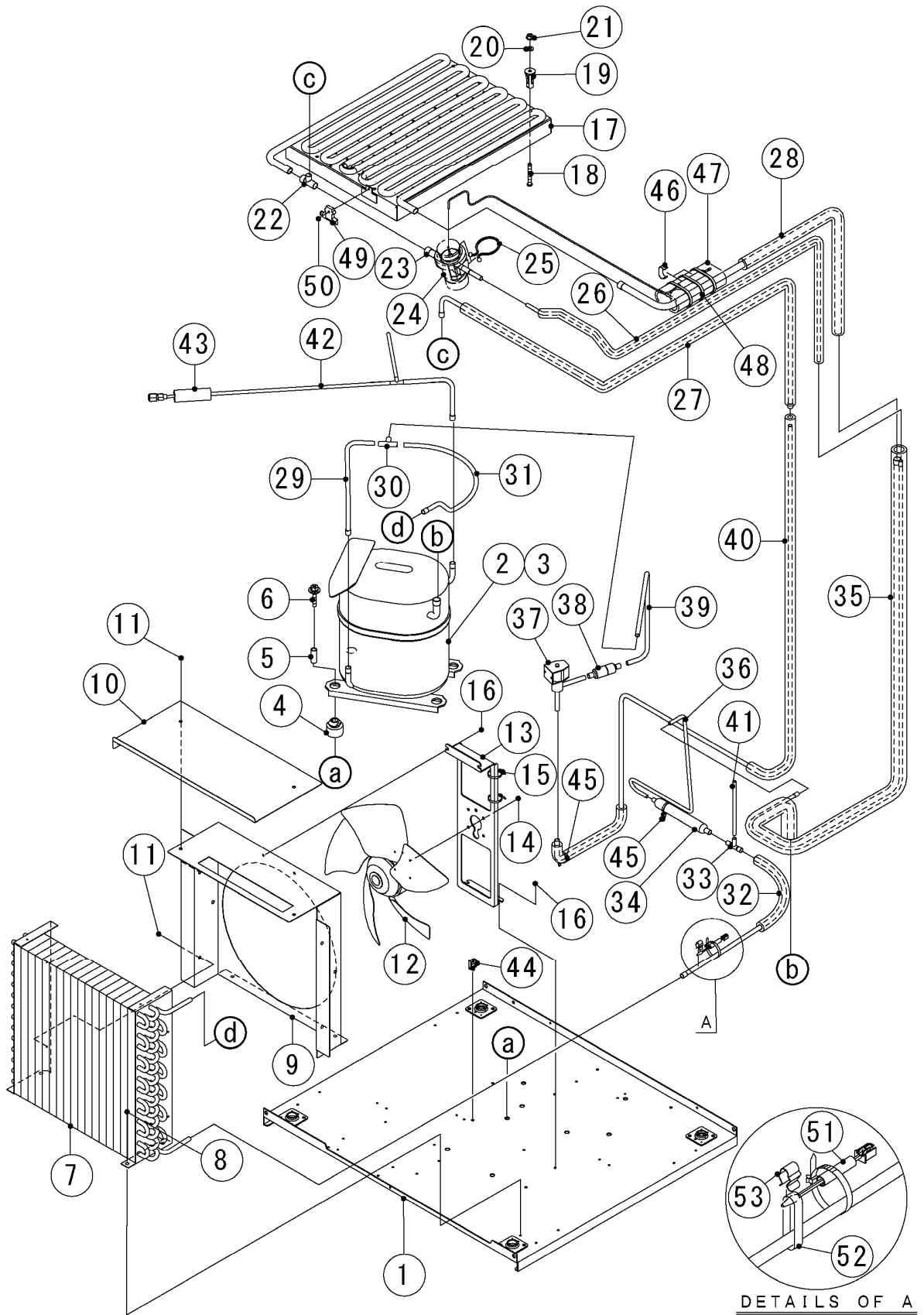

DETAILS OF A

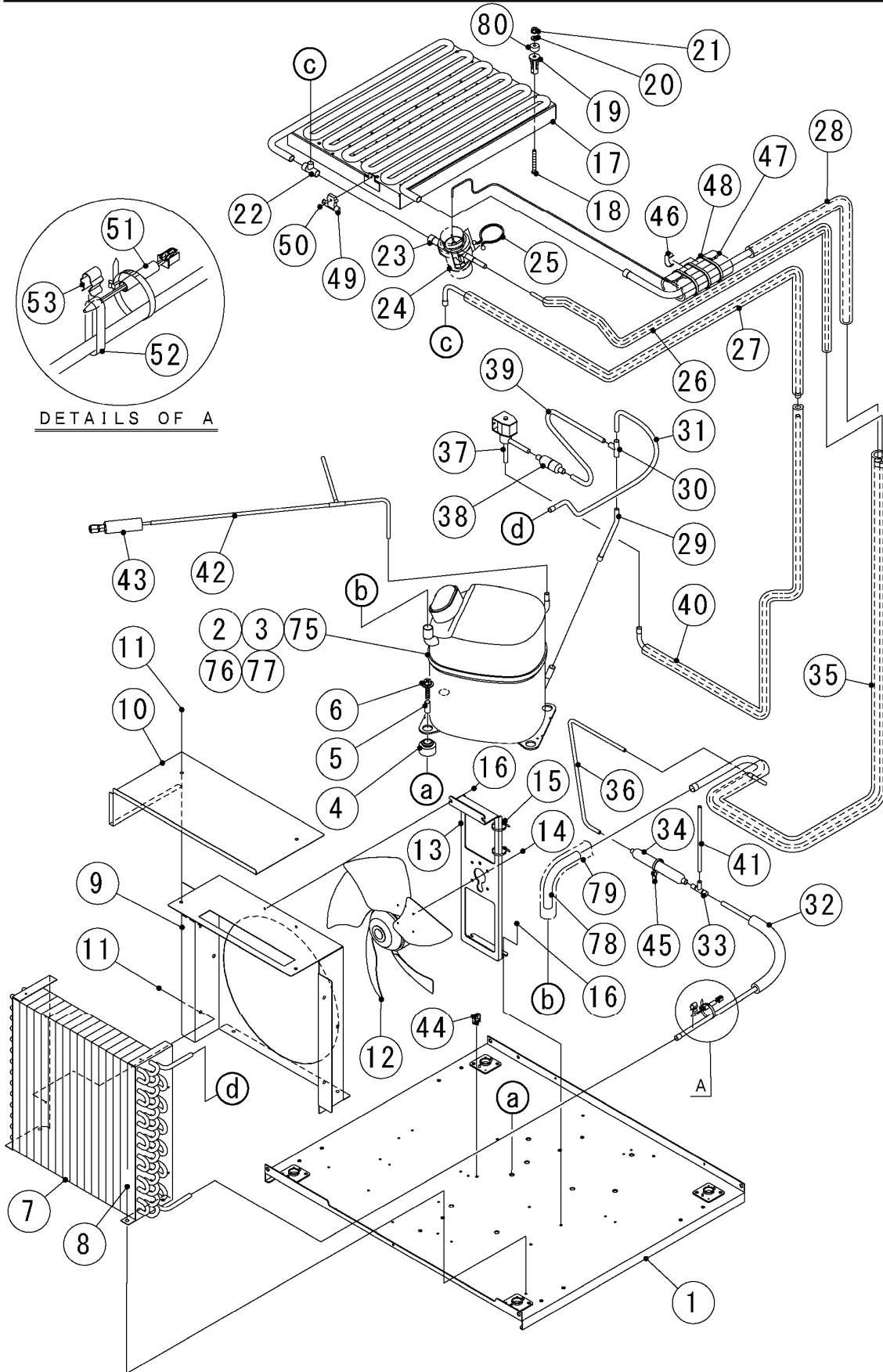

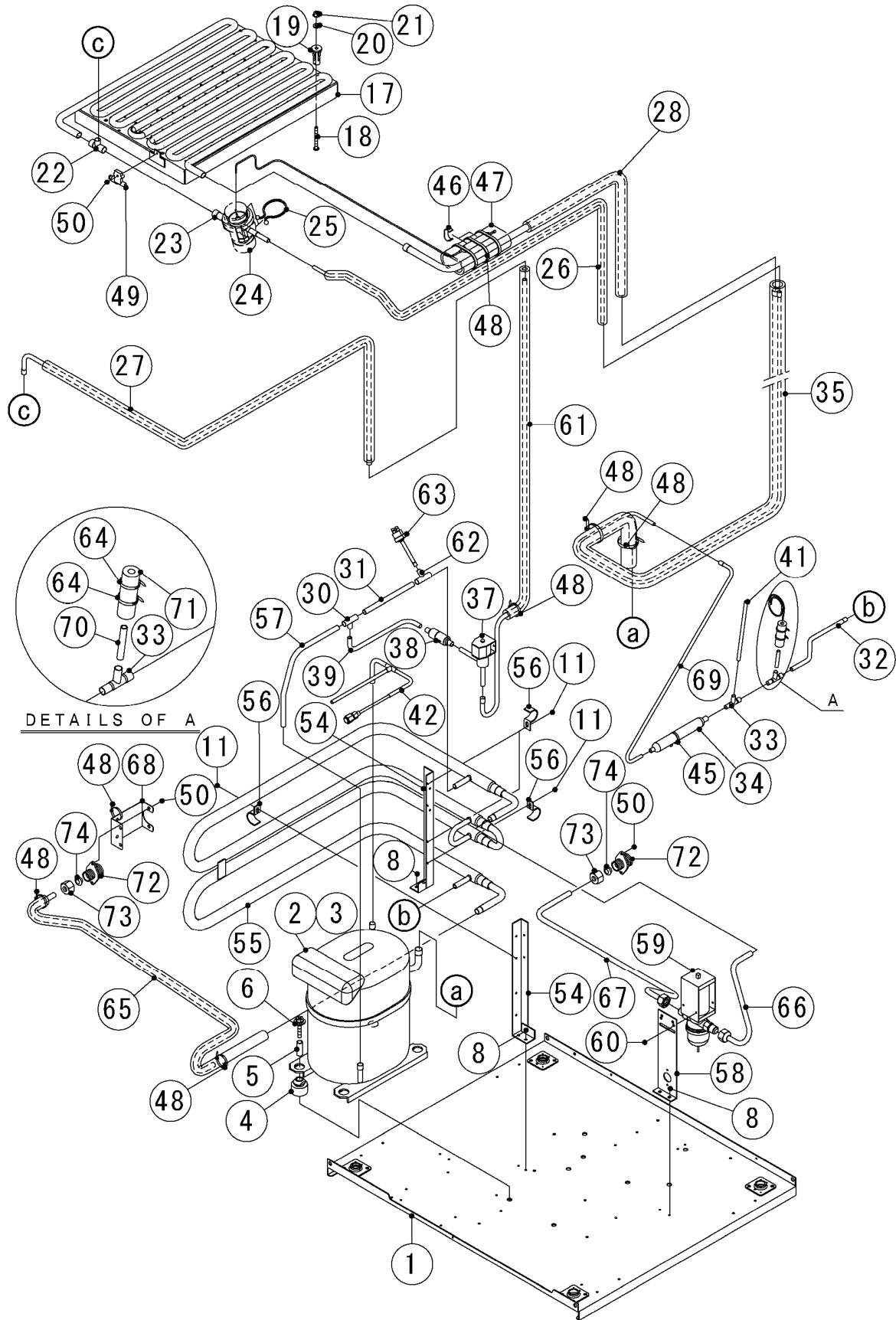

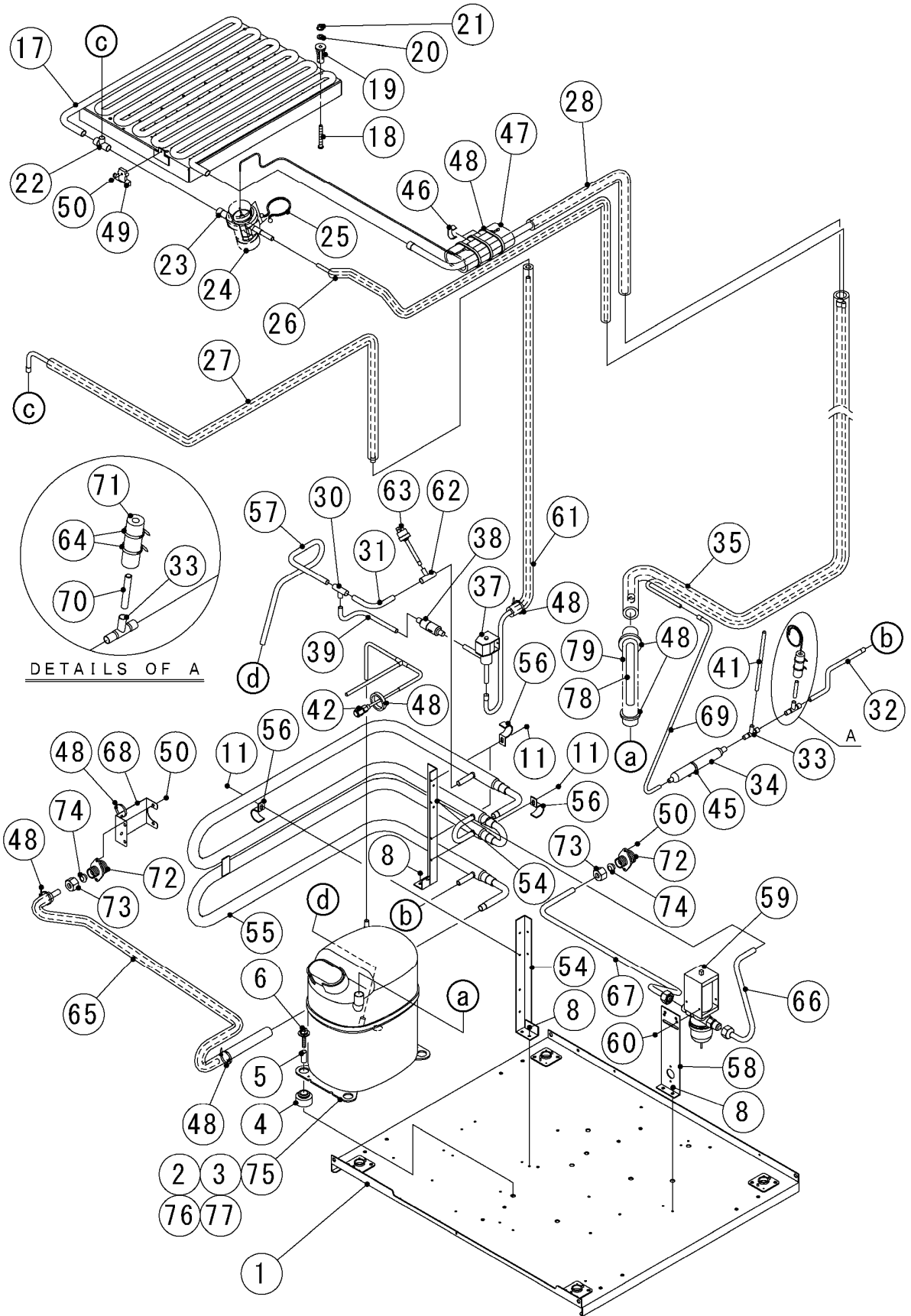

HE,GRAM

MODEL: IM-240NE,-21,-23 IM-240WNE,-23				TITLE: B.REFRIGERATION ASSY				
INDEX NO.	DESCRIPTION	MATERIAL OR MODEL NUMBER	PART NUMBER	REQ'D NUMBER				
				A-1,B-0 B-1	B-2 B-3	B-4,C-0 D-0,E-0		
1	BASE	(240NE,-21,-23)	3Y5423G01	1	-	-		
			3Y6768G01	-	1	1		
		(240WNE,-23)	3Y5539G01	1	-	-		
			3Y6772G01	-	1	1		
2	COMPRESSOR		4A1581-01	1	-	-		
			P01855-01	-	1	1		
3	MOTOR PROTECTOR		4A1581F01	1	1	1		
4	GROMMET		434922-02	4	-	-		
	RUBBER GROMMET		P01858-01	-	4	4		
5	SPACER		434921-01	4	-	-		
	SLEEVE		P01859-01	-	4	4		
6	BOLT		436206-04	4	-	-		
			436206-03	-	4	4		
7	CONDENSER	(240NE,-21,-23)	P03307-01	1	1	1		
8	FLANGE BOLT (S-TITE)	(240NE,-21,-23)	FTR0408M0	2	2	2		
		(240WNE,-23)		6	6	6		
9	SHROUD	(240NE,-21,-23)	2H9947M01	1	1	1		
10	PLATE - COND	(240NE,-21,-23)	4Y6996M01	1	-	-		
			4Y7848M01	-	1	1		
11	TRUSS HEAD TAPPING SCREW T2	(240NE,-21,-23)	FT20408F0	6	6	6		
		(240WNE,-23)		4	4	4		
12	FAN MOTOR	(240NE,-21,-23)	P02545-01	1	1	1		
13	BRACKET - FM	(240NE,-21,-23)	3Y5075M01	1	1	1		
14	HEX HEAD BOLT (SPRING WASHER AND FLAT WASHER)	(240NE,-21,-23)	FBK0408F0	5	5	5		
15	TIE	(240NE,-21,-23)	7920-0002	2	2	2		
16	HEX HEAD BOLT (SPRING WASHER AND FLAT WASHER)	(240NE,-21,-23)	FBK0510F0	4	4	4		
17	EVAPORATOR		2H7526G02	1	1	1		
			(240NE-21)	208205G04	-	1	1	
			(240NE-23)(240WNE-23)	2H1833G03	1	1	1	
18	SCREW EVAPORATOR		4Y4922M02	4	4	4		
			(240NE-21,-23)(240WNE-23)	4Y4922M03	4	4	4	
19	COLLAR		3H3879-01	4	4	4		
20	WASHER		4H0777-01	4	4	4		
21	FLANGE NUT		FNHF06S0	4	4	4		

HE,GRAM

MODEL: IM-240NE,-21,-23 IM-240WNE,-23				TITLE: B.REFRIGERATION ASSY			
INDEX NO.	DESCRIPTION	MATERIAL OR MODEL NUMBER	PART NUMBER	REQ'D NUMBER			
				A-1,B-0 B-1	B-2 B-3	B-4,C-0 D-0,E-0	
22	TEE		430608-01	1	1	1	
23	EXPANSION VALVE		P01874-01	1	1	1	
24	VALVE COVER		3Y3051P01	1	1	1	
25	CLAMP		P00752-01	2	2	2	
26	COPPER TUBE(D) - HIGH SIDE		3Y5424G01	1	1	1	
27	COPPER TUBE(C) - HOT GAS		3Y5425G01	1	1	1	
28	COPPER TUBE(A) - LOW SIDE		3Y5426G01	1	1	1	
29	COPPER TUBE(A) - HIGH SIDE	(240NE,-21,-23)	4Y6992M01	1	-	-	
			4Y7844M01	-	1	1	
30	TEE	(240NE,-21,-23)	420041-11	1	1	1	
		(240WNE,-23)	420041-09	1	1	1	
31	COPPER TUBE(A-2) - HIGH SIDE	(240NE,-21,-23)	4Y6993M01	1	-	-	
			4Y7843M01	-	1	1	
		(240WNE,-23)	4Y7079M01	1	-	-	
			4Y7834M01	-	1	1	
32	COPPER TUBE(B) - HIGH SIDE	(240NE,-21,-23)	4Y6994G01	1	-	-	
			4Y7845G01	-	1	1	
		(240WNE,-23)	4Y7080M01	1	1	1	
33	TEE	(240NE,-21,-23)	4Y4060Z01	1	1	1	
		(240WNE,-23)		2	2	2	
34	DRIER		458776-01	1	1	1	
35	HEAT EXCHANGER	(240NE,-21,-23)	2X0289G01	1	-	-	
			2X1258G01	-	1	1	
		(240WNE,-23)	2X0364G01	1	-	-	
			2X1267G01	-	1	1	
36	COPPER TUBE(B2) - HIGH SIDE	(240NE,-21,-23)	4Y7057M01	1	-	-	
			4Y7846M01	-	1	1	
37	HOT GAS VALVE		P01871-01	1	1	1	
38	STRAINER		P00812-01	1	1	1	
39	COPPER TUBE(A) - HOT GAS	(240NE,-21,-23)	3Y5427M01	1	-	-	
			4Y7847M01	-	1	1	
		(240WNE,-23)	4Y7082M01	1	-	-	
			4Y7835M01	-	1	1	
40	COPPER TUBE(B) - HOT GAS	(240NE,-21,-23)	2X0290G01	1	-	-	
			2X1259G01	-	1	1	
41	PROCESS TUBE		4Y0273-01	1	1	1	

HE,GRAM

MODEL: IM-240NE,-21,-23 IM-240WNE,-23				TITLE: B.REFRIGERATION ASSY			
INDEX NO.	DESCRIPTION	MATERIAL OR MODEL NUMBER	PART NUMBER	REQ'D NUMBER			
				A-1,B-0 B-1	B-2 B-3	B-4,C-0 D-0,E-0	
42	COPPER TUBE(G) - PROCESS	(240NE,-21,-23)	3Y5508G01	1	-	-	
			3Y6767G01	-	1	1	
		(240WNE,-23)	3Y5534G01	1	-	-	
			3Y6759G01	-	1	1	
43	INSULATION TUBE	(240NE,-21,-23)	H71323070	1	1	1	
44	WIRE SADDLE	(240NE,-21,-23)	428060-03	1	1	1	
45	TIE	(240NE,-21,-23)	457167-01	2	-	-	
				-	1	1	
		(240WNE,-23)		1	1	1	
46	CLIP		452254-02	2	2	2	
47	INSULATION		4X8643-01	1	1	1	
48	TIE	(240NE,-21,-23)	7920-0003	3	3	3	
		(240WNE,-23)		9	-	-	
				-	10	10	
49	HOLDER - THERMISTOR		3H9642-01	1	1	1	
50	TRUSS HEAD TAPPING SCREW	(240NE,-21,-23)	FTS0408M0	1	1	1	
	(S-TITE)	(240WNE,-23)		5	5	5	
51	THERMISTOR(G) - FILTER	(240NE,-21,-23)	4Y4859G01	1	1	1	
52	ALUMINUM TAPE	(240NE,-21,-23)	1H4761-01	1	-	-	
			1H5213Z01	-	1	1	
53	CLIP - THERMISTOR	(240NE,-21,-23)	4R2938-01	1	1	1	
54	BRACKET CONDENSER	(240WNE,-23)	425490-01	2	2	2	
55	CONDENSER - WATER COOLED	(240WNE,-23)	103099G01	1	1	1	
56	CLAMP(B) - CONDENSER	(240WNE,-23)	4H0622-01	4	4	4	
57	PIPE(A-1) - HIGH SIDE	(240WNE,-23)	3Y5531M01	1	-	-	
			4Y7836M01	-	1	1	
58	BRACKET - WATER REGURATOR	(240WNE,-23)	4X5632-01	1	1	1	
59	WATER REGULATOR	(240WNE,-23)	456441-01	1	1	1	
60	TRUSS HEAD MACHINE SCREW	(240WNE,-23)	FST0408S0	2	2	2	
61	COPPER TUBE (B) - HOT GAS	(240WNE,-23)	2X0365G01	1	1	1	
62	TEE	(240WNE,-23)	420041-05	1	1	1	
63	PRESSURE SWITCH	(240WNE,-23)	459863-03	1	1	1	
64	NYLON TIE	(240WNE,-23)	7920-0002	2	2	2	
65	COPPER TUBE(A) - WATER	(240WNE,-23)	3Y5540G01	1	1	1	
66	COPPER TUBE (B) - WATER	(240WNE,-23)	3Y5541G01	1	1	1	
67	COPPER TUBE (C) - WATER	(240WNE,-23)	3Y5542G01	1	1	1	

HE,GRAM

MODEL: IM-240NE,-21,-23 IM-240WNE,-23			TITLE: B.REFRIGERATION ASSY				
INDEX NO.	DESCRIPTION	MATERIAL OR MODEL NUMBER	PART NUMBER	REQ'D NUMBER			
				A-1,B-0 B-1	B-2 B-3	B-4,C-0 D-0,E-0	
68	BRACKET - WATER PIPE	(240WNE,-23)	4Y7086M01	1	1	1	
69	COPPER TUBE(C) - HIGH SIDE	(240WNE,-23)	4Y7081M01	1	-	-	
			4Y7850M01	-	1	1	
70	TUBE - CAPILLARY	(240WNE,-23)	4X4276-01	1	1	1	
71	INSULATION - CAP	(240WNE,-23)	4H9594-01	1	1	1	
72	FITTING(P)	(240WNE,-23)	3Y0747-01	2	2	2	
73	NUT (A) - FITTING	(240WNE,-23)	415713-03	2	2	2	
74	TAPPERED PACKING	(240WNE,-23)	415715-01	2	2	2	
75	COVER		P01857-01	-	1	1	
76	CLAMP		P01862-01	-	1	1	
77	GASKET		P01863-01	-	1	1	
78	COPPER TUBE(D)-LOW SIDE		4Y7817M01	-	1	1	
79	INSULATION TUBE	(240NE,-21,-23)	H72030400	-	1	1	
		(240WNE,-23)	H72030250	-	1	1	
80	WASHER	(240NE-21)	4H1365-06	-	4	4	
		(240NE-23)(240WNE-23)	4H1365-05	4	4	4	

HE,GRAM

MODEL: IM-240NE,-21,-23 IM-240WNE,-23				TITLE: C.MECHANISM ASSY			
INDEX NO.	DESCRIPTION	MATERIAL OR MODEL NUMBER	PART NUMBER	REQ'D NUMBER			
				A-1,B-0 B-1	B-2 B-3	B-4,C-0 D-0,E-0	
J	ACTUATOR MOTOR ASSY		3Y8847A01	1	1	1	
K	WATER PAN ASSY		1H4689A01	1	1	1	
L	BIN SWITCH AY		3Y5430A01	1	1	1	
1	FRAME - FRONT		3Y5428M01	1	1	1	
2	FRAME - REAR		3Y5429M01	1	1	1	
3	TRUSS HEAD MACHINE SCREW		FST0512S0	2	2	2	
4	FLANGE NUT		FNHF05S0	6	6	6	
5	BEARING - CAM SHAFT		3X8307-02	1	1	1	
6	TRUSS HEAD MACHINE SCREW		FST0516S0	4	4	4	
7	CAM SHAFT		425511G01	1	1	1	
8	BEARING - CAM SHAFT		3X8307-02	1	1	1	
9	CAM (B)		376546P01	1	1	1	
10	COTTER PIN		711S-0212	1	1	1	
11	EXTEN SPRING		4H3473-01	1	1	1	
12	BEARING PLATE		3H1440G03	2	2	2	
13	BEARING PLATE		3H1440G04	-	-	-	
14	FLANGE NUT		FNHF06S0	4	4	4	
15	SHAFT (B)		4H1184-02	2	2	2	
16	SNAP PIN		715S-0006	2	2	2	
17	FRAME - BIN SW		4Y6997M01	1	1	1	
18	FLANGE BOLT		FBF0410M0	4	4	4	
19	BRACKET - BIN SW		4Y6998M01	1	1	1	
20	TRUSS HEAD TAPPING SCREW T2		FT20410M0	2	2	2	
21	GUIDE - CONNECTOR		4H5619-01	1	1	1	
22	COLLAR	(240NE-21)	429124-01	-	1	1	

IM-240NE(-23)
IM-240WNE

D. CONTROL BOX ASSY

(A-1) to (B-1)

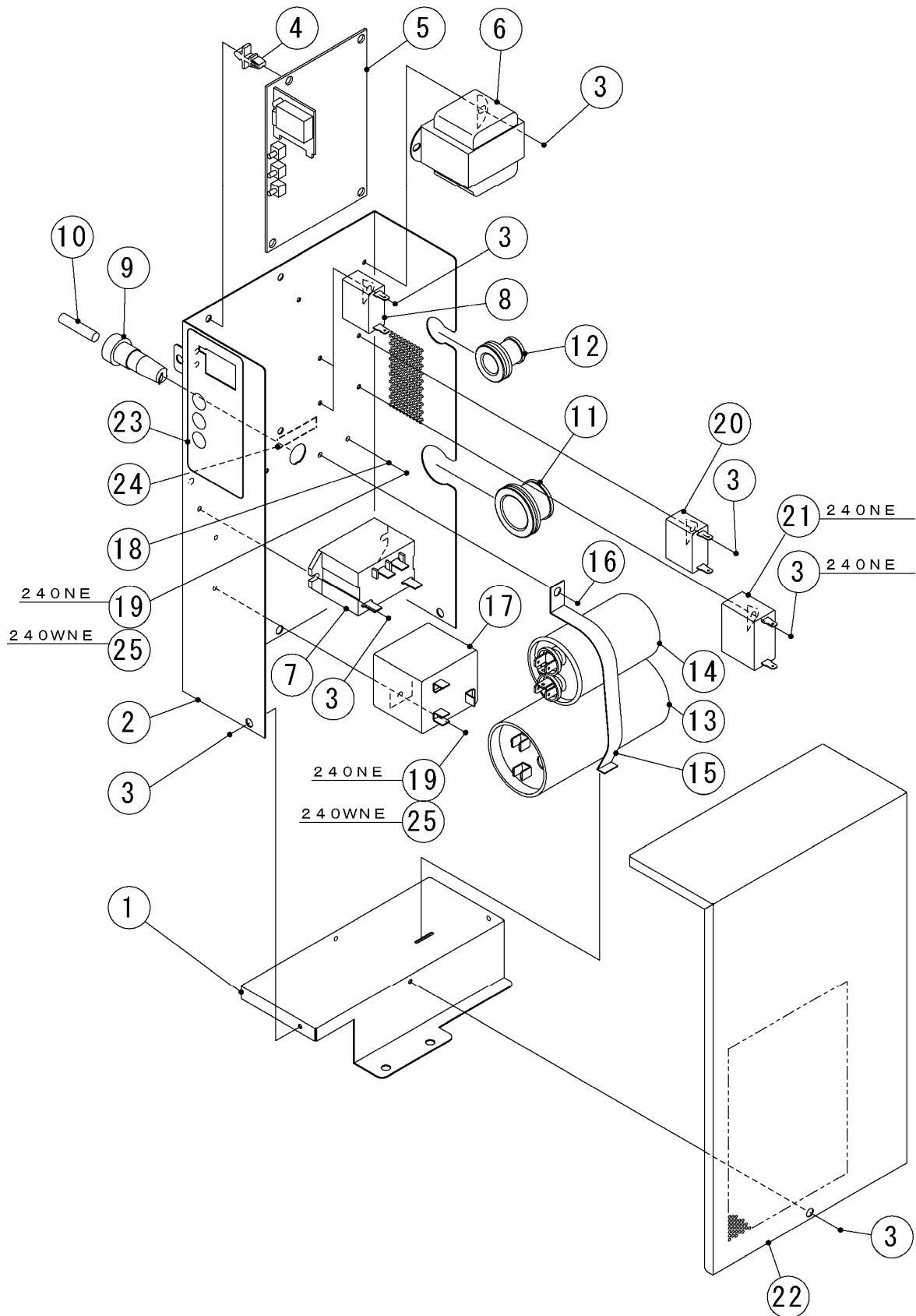

IM-240NE(-21,-23)
IM-240WNE(-23)

D. CONTROL BOX ASSY

(B-2) and later

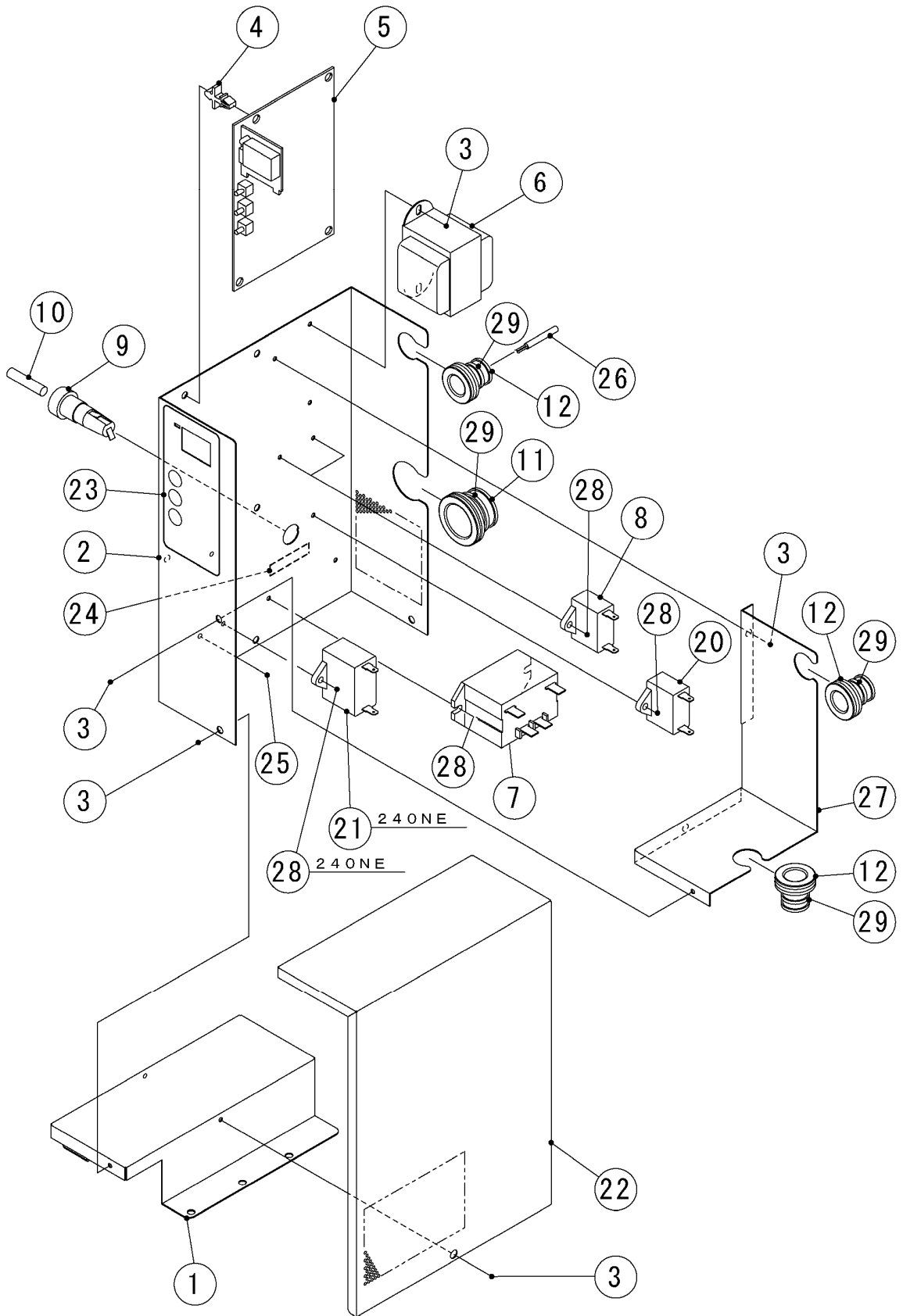

HE,GRAM

MODEL: IM-240NE,-21,-23 IM-240WNE,-23				TITLE: D.CONTROL BOX ASSY			
INDEX NO.	DESCRIPTION	MATERIAL OR MODEL NUMBER	PART NUMBER	REQ'D NUMBER			
				A-1,B-0 B-1	B-2 B-3	B-4,C-0 D-0,E-0	
1	CONTROL BOX B		3Y5431M01	1	-	-	
	CONTROLBOX - BASE		3Y6722M01	-	1	1	
2	CONTROL BOX - BODY G		3Y5432G01	1	-	-	
	CONTROL BOX(B)		2X1053M01	-	1	-	
			2X1251M01	-	-	1	
3	TRUSS HEAD TAPPING SCREW T2	(240NE,-21,-23)	FT20408F0	12	9	9	
		(240WNE,-23)		11			
4	BOARD SUPPORT		414929-02	4	4	4	
5	CONTROLLER BOARD		P01873-01	1	1	1	
6	TRANSFORMER		P02714-01	1	1	1	
7	POWER RELAY		P00034-01	1	1	1	
8	CAPACITOR		P01870-01	2	2	2	
9	FUZE HOLDER		P00014-01	1	1	-	
			P02829-01	-	-	1	
10	FUZE		P01876-01	1	1	-	
			P01992-01	-	-	1	
11	GROMMET		4H2568-01	1	1	1	
12	GROMMET		4H2568-02	1	3	3	
13	START CAPACITOR	3535B7C0064A250A5	3A0076-14	1	-	-	
14	CAPACITOR - RUN		3A2005-01	1	-	-	
15	BAND		427254-01	1	-	-	
16	FLANGE BOLT (S-TITE)		FTR0408M0	1	-	-	
17	STARTER		4A1107-02	1	-	-	
18	SPRING WASHER		FWSP04S0	1	-	-	
19	TRUSS HEAD TAPPING SCREW	(240NE,-23)	FTS0408M0	2	-	-	
	(S-TITE)						
20	CAPACITOR		P01910-01	1	1	1	
21	CAPACITOR	(240NE,-21,-23)	P01865-01	1	1	1	
22	CONTROL BOX - COVER		3Y5371M01	1	-	-	
	CONTROL BOX COVER		3Y6513M01	-	1	1	
23	CONTROL LABEL		475642L01	1	1	1	
24	LABEL - FUZE		466798-01	1	1	1	
25	TRUSS HEAD MACHINE SCREW		FST0408S0	2	1	1	
26	THERMISTOR-CUBE COTROL		P00350-04	-	1	1	
27	SEPARATOR - BOX		3Y6512M01	-	1	1	

HE,GRAM

MODEL: IM-240NE,-21,-23 IM-240WNE,-23				TITLE: D.CONTROL BOX ASSY			
INDEX NO.	DESCRIPTION	MATERIAL OR MODEL NUMBER	PART NUMBER	REQ'D NUMBER			
				A-1,B-0 B-1	B-2 B-3	B-4,C-0 D-0,E-0	
28	TRUSS HEAD TAPPING SCREW T2	(240NE,-21,-23)	FT20410F0	-	6	6	
		(240WNE,-23)		-	5	5	
29	TIE		7920-0003	-	4	4	

IM-240NE(-21,-23)
IM-240WNE(-23)

E. WATER CIRCUIT ASSY

(A-1) and later

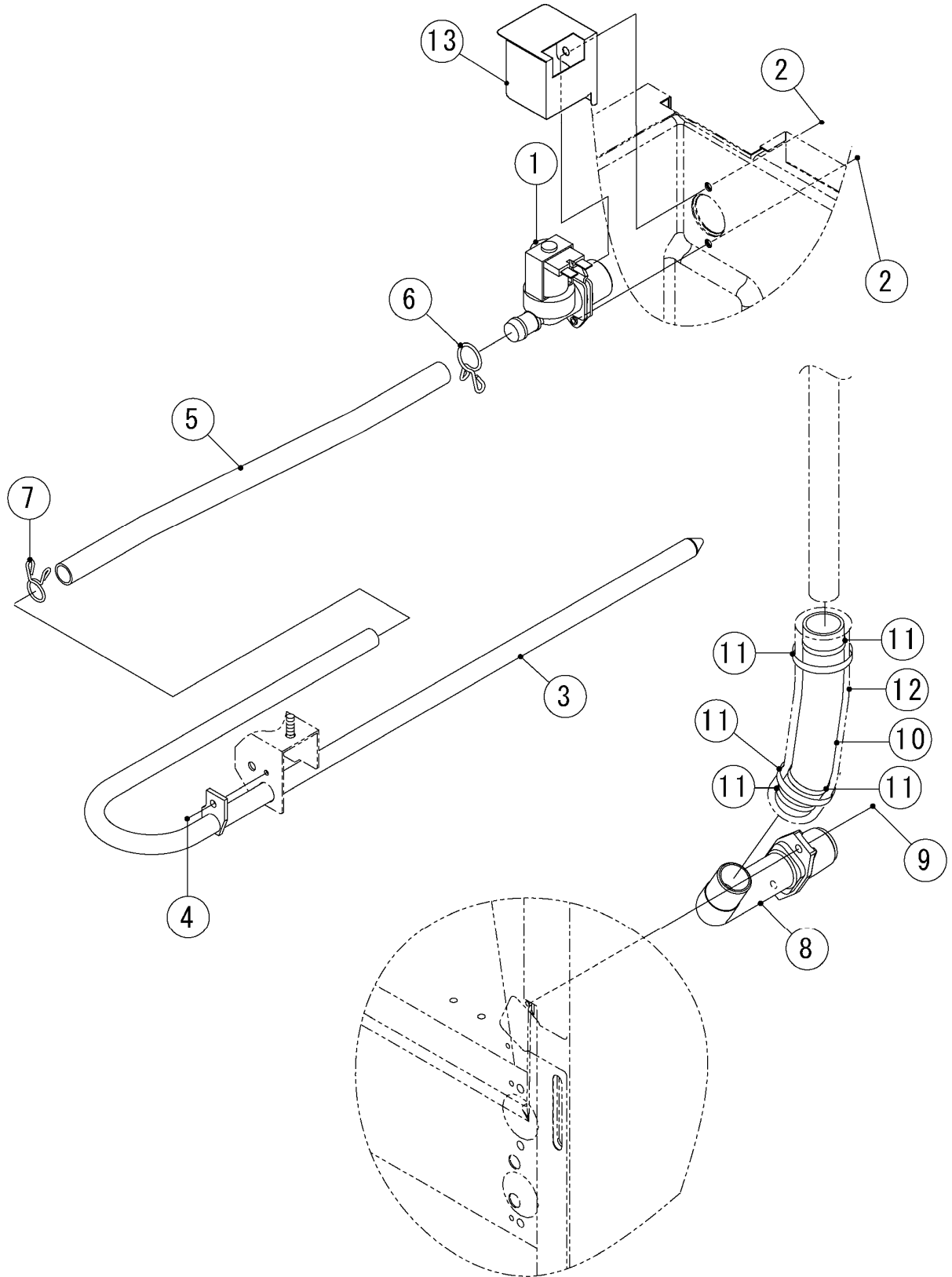

HE,GRAM

MODEL: IM-240NE,-21,-23 IM-240WNE,-23				TITLE: E.WATER CIRCUIT ASSY			
INDEX NO.	DESCRIPTION	MATERIAL OR MODEL NUMBER	PART NUMBER	REQ'D NUMBER			
				A-1,B-0 B-1	B-2 B-3	B-4,C-0 D-0,E-0	
1	WATER VALVE		P02056-01	1	1	1	
2	HEX HEAD BOLT (SPRING WASHER AND FLAT WASHER)		FBK0410S0	2	2	2	
3	WATER SUPPLY PIPE		3H9533G01	1	1	1	
4	TRUSS HEAD MACHINE SCREW		FST0408S0	1	1	1	
5	SILICONE HOSE		4Y6912R02	1	1	1	
6	HOSE CLAMP		435934-03	1	1	1	
7	HOSE CLAMP		435934-02	1	1	1	
8	DRAIN PIPE		3H0394-01	1	1	1	
9	TRUSS HEAD TAPPING SCREW T2		FT20410M0	2	2	2	
10	VINYL HOSE		2X0293-01	1	1	1	
11	TIE	CV-150	7920-0003	5	5	5	
12	INSULATION HOSE - DRAIN		4Y7055Z01	1	1	1	
13	COVER-WATER VALVE		3Y6277M01	1	1	1	

IM-240NE(-21,-23)
IM-240WNE(-23)

F. DOOR ASSY

(A-1) and later

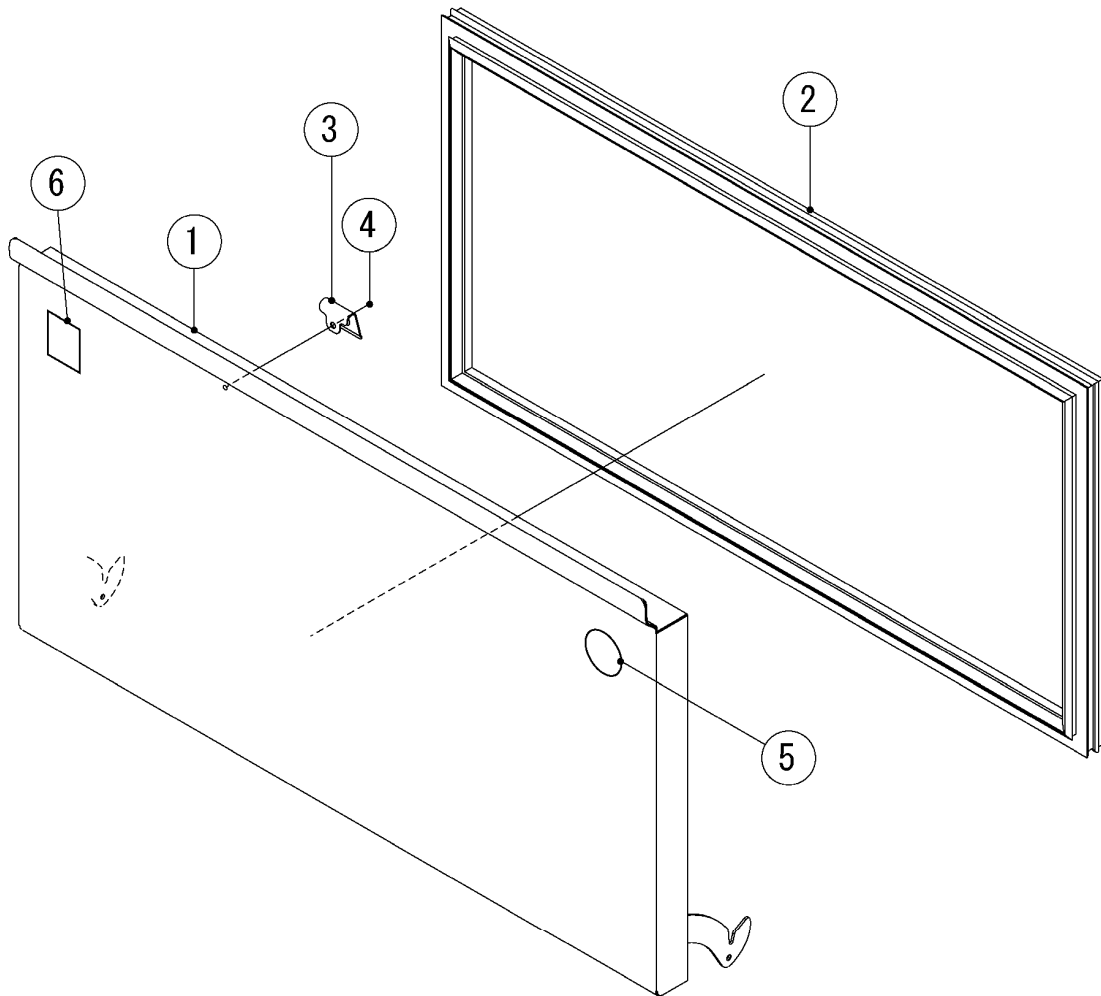

HE,GRAM

MODEL: IM-240NE,-21,-23 IM-240WNE,-23		TITLE: F.DOOR ASSY					
INDEX NO.	DESCRIPTION	MATERIAL OR MODEL NUMBER	PART	REQ'D NUMBER			
			NUMBER	A-1,B-0 B-1	B-2 B-3	B-4,C-0 D-0,E-0	
1	DOOR G		3Y5435G01	1	1	1	
2	DOOR GASKET		3Y6199P04	1	1	1	
3	CATCH - SLOPE		4X7644-01	1	1	1	
4	TRUSS HEAD TAPPING SCREW T2		FT20408M0	1	1	1	
5	LABEL - PENGUIN	(HE)	471486L01	1	1	1	
6	LABEL - HACCP		476519L01	1	1	1	

IM-240NE(-21,-23)
IM-240WNE(-23)

G. FRONT COVER UPPER ASSY (A-1) and later

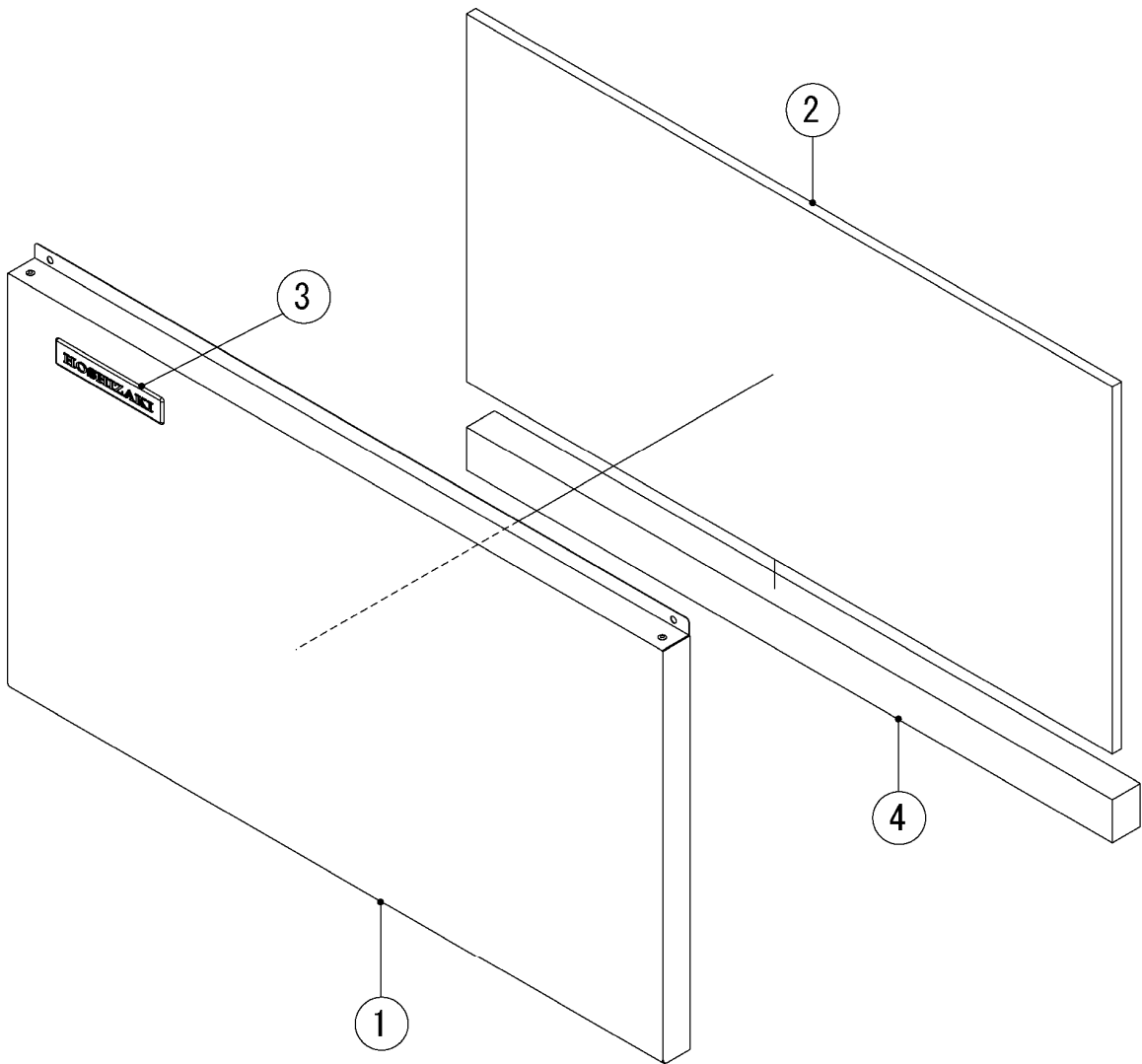

HE,GRAM

MODEL: IM-240NE,-21,-23 IM-240WNE,-23		TITLE: G.FRONT COVER UPPER ASSY					
INDEX NO.	DESCRIPTION	MATERIAL OR MODEL NUMBER	PART NUMBER	REQ'D NUMBER			
				A-1,B-0 B-1	B-2 B-3	B-4,C-0 D-0,E-0	
1	FRONT COVER UPPER		3Y5437G01	1	1	1	
2	INSULATION - FRONT(A)		4Y7327P01	1	1	1	
3	EMBLEM	(HE)	340842-01	1	1	1	
	EMBLEM-GRAM	(GRAM)	4Y6123L01	-	-	1	
4	INSULATION - FRONT(B)		4Y7328P01	1	1	1	

IM-240NE(-21,-23)

IM-240WNE(-23) H. FRONT COVER (LOWER) ASSY (A-1) and later

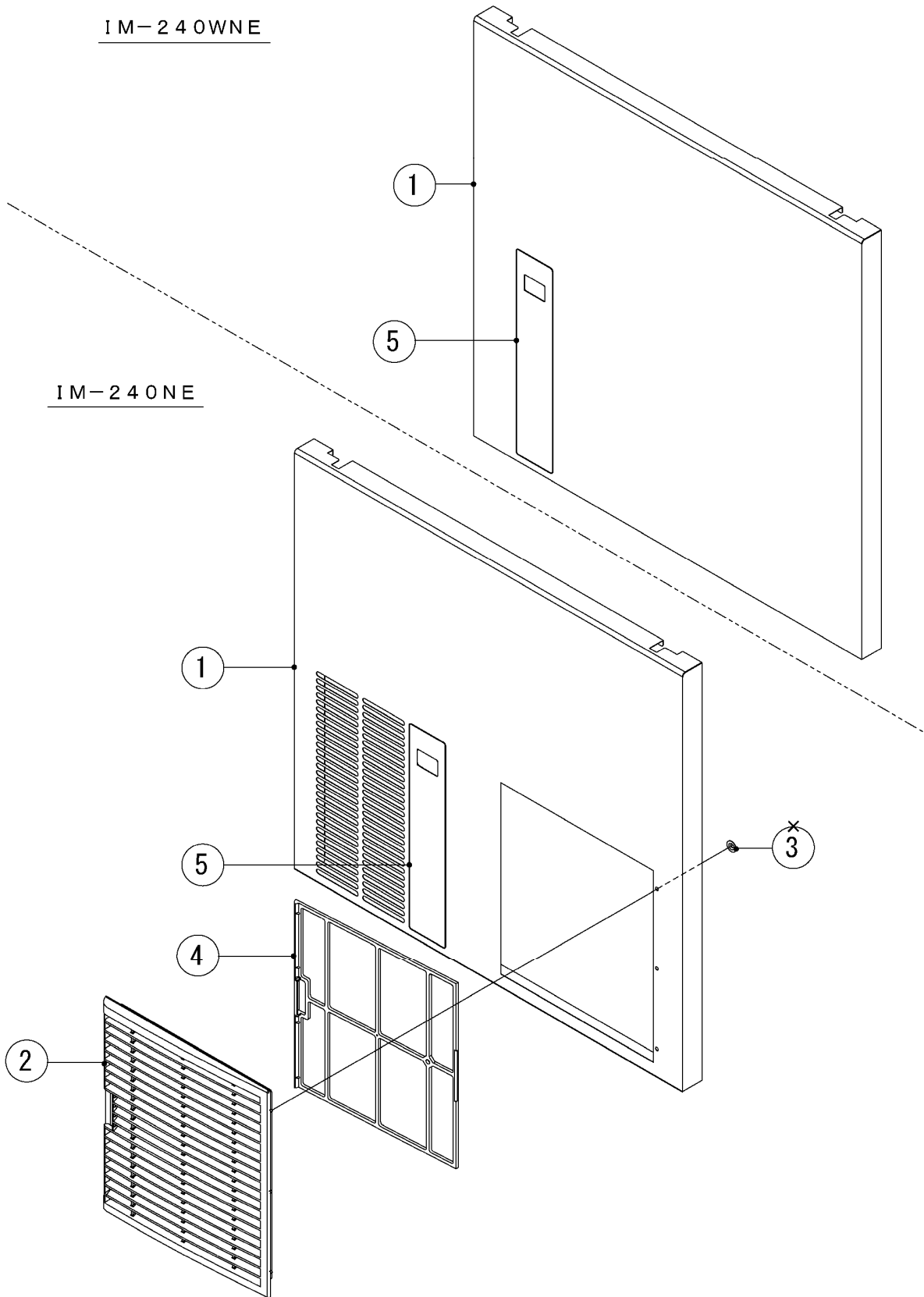

HE,GRAM

MODEL: IM-240NE,-21,-23 IM-240WNE,-23				TITLE: H.FRONTCOVER(LOWER) ASSY			
INDEX NO.	DESCRIPTION	MATERIAL OR MODEL NUMBER	PART NUMBER	REQ'D NUMBER			
				A-1,B-0 B-1	B-2 B-3	B-4,C-0 D-0,E-0	
1	FRONT COVER LOWER	(240NE,-21,-23)	3Y5546G01	1	-	-	
			3Y6769G01	-	1	1	
		(240WNE,-23)	3Y5545G01	1	-	-	
			3Y6775G01	-	1	1	
2	LOUVER A	(240NE,-21,-23)	1A0547-01	1	-	-	
			121931P01	-	1	1	
3	PUSH RETAINER	(240NE,-23)	4A2414-01	3	-	-	
4	AIR FILTER A	(240NE,-21,-23)	2A2062G01	1	-	-	
			262259G01	-	1	1	
5	OPERATION LABEL		375116L01	1	-	-	
			375116L04	-	1	1	

IM-240NE(-21,-23)
IM-240WNE(-23)

J. ACTUATOR MOTOR ASSY

(A-1) and later

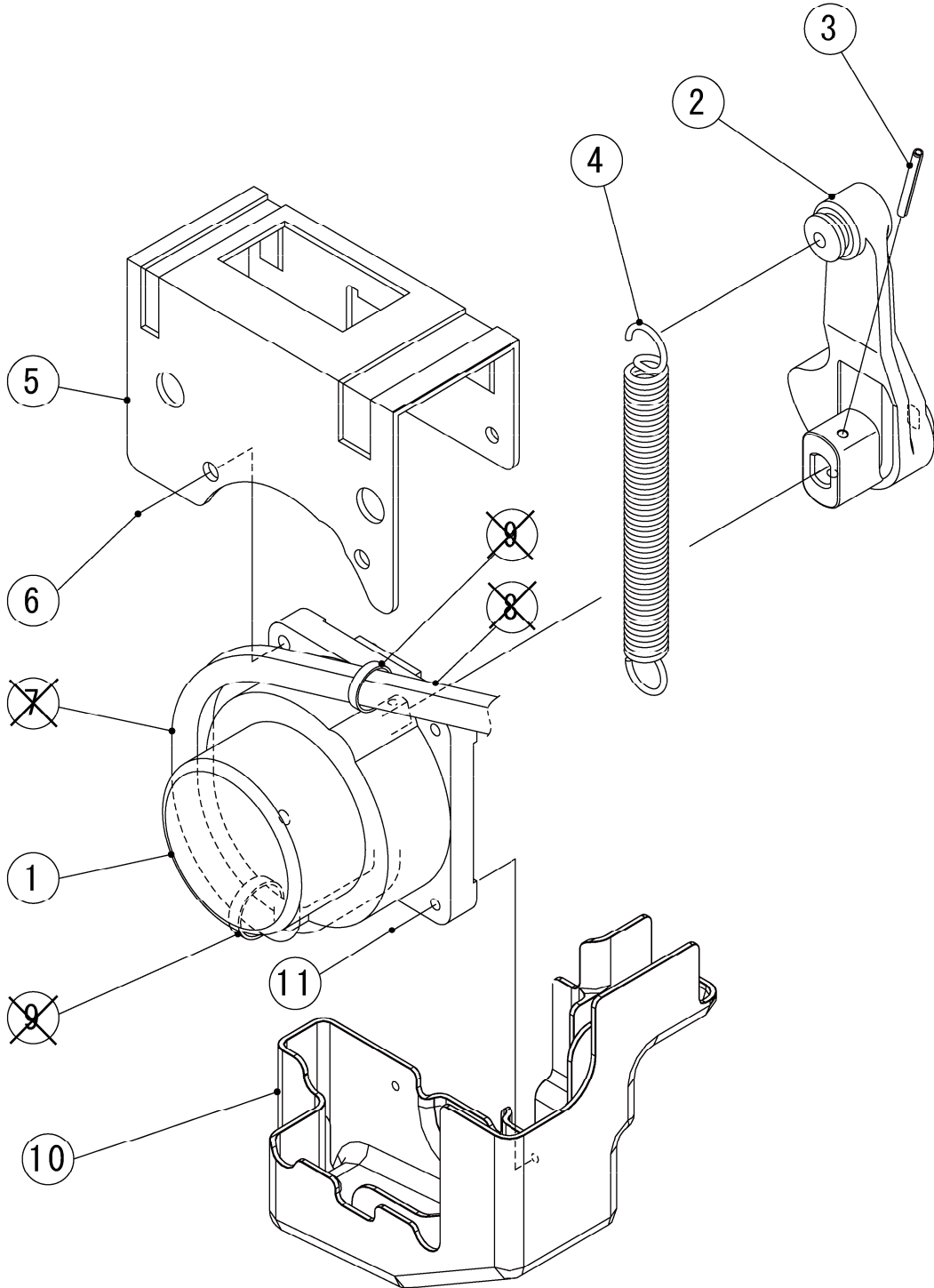

HE,GRAM

MODEL: IM-240NE,-21,-23 IM-240WNE,-23				TITLE: J.ACTUATOR MOTOR ASSY			
INDEX NO.	DESCRIPTION	MATERIAL OR MODEL NUMBER	PART NUMBER	REQ'D NUMBER			
				A-1,B-0 B-1	B-2 B-3	B-4,C-0 D-0,E-0	
1	ACTUATOR MOTOR		4Y8998G01	1	1	1	
2	CAM(A)		306543G03	1	1	1	
3	SPRING PIN	3*28	712S-0328	1	1	1	
4	EXTEN SPRING		4H3473-01	1	1	1	
5	BRACKET - AM		3Y2924M01	1	1	1	
6	HEX HEAD BOLT (SPRING WASHER AND FLAT WASHER)		FBK0620S0	2	2	2	
7	TUBE-SILICONE		4Y6751Z03	-	-	-	
8	TUBE-SILICONE		4X8017-07	-	-	-	
9	TIE	CV-150	7920-0003	-	-	-	
10	COVER - ACTUATOR MOTOR		1H4881P01	1	1	1	
11	T2 TRUSS HEAD SCREW		FT20418M0	2	2	2	

IM-240NE(-21,-23)
IM-240WNE(-23)

K. WATER PAN ASSY

(A-1) and later

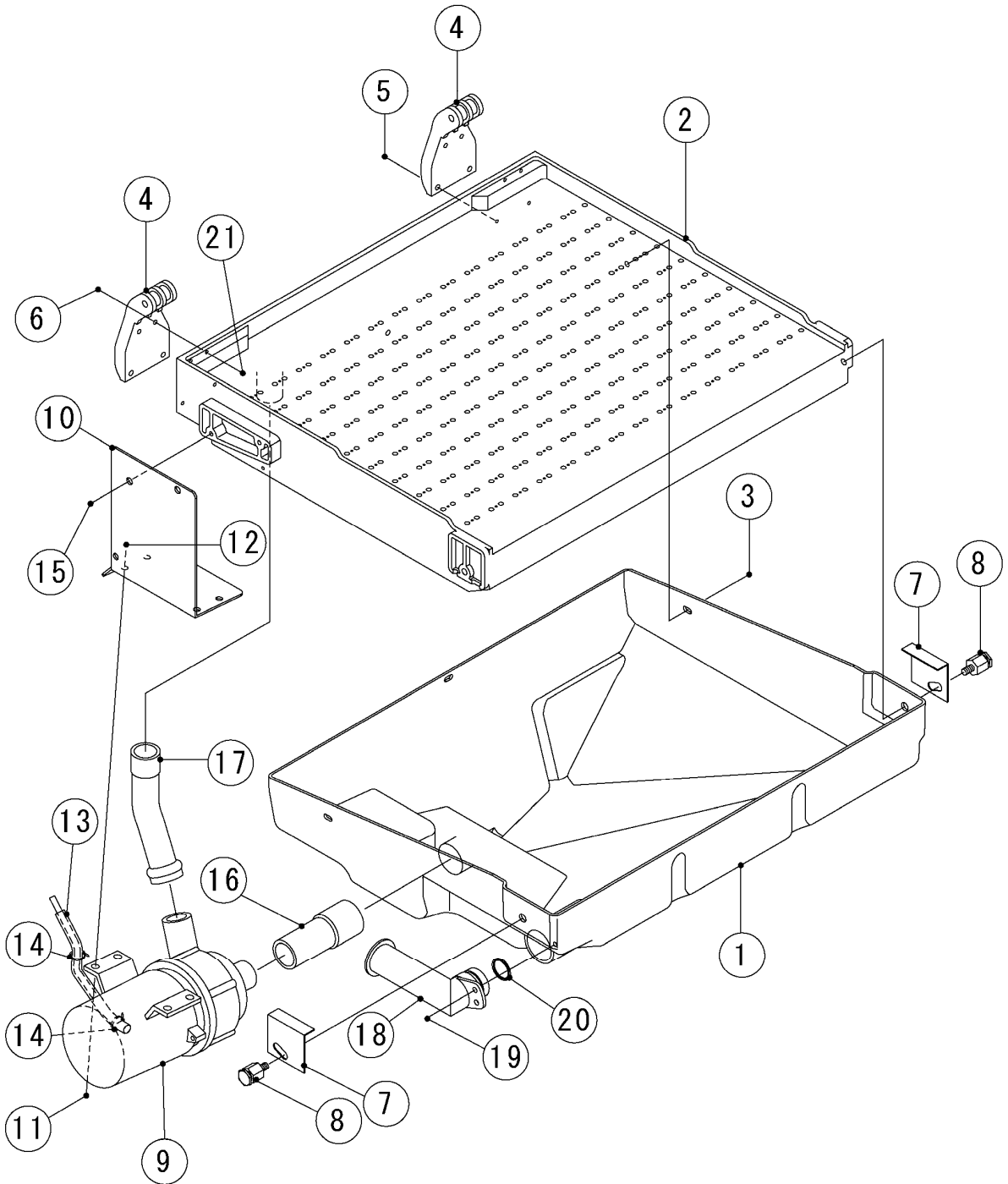

HE,GRAM

MODEL: IM-240NE,-21,-23 IM-240WNE,-23				TITLE: K.WATER PAN ASSY			
INDEX NO.	DESCRIPTION	MATERIAL OR MODEL NUMBER	PART NUMBER	REQ'D NUMBER			
				A-1,B-0 B-1	B-2 B-3	B-4,C-0 D-0,E-0	
1	WATER PAN		1H0888-02	1	1	1	
2	WATER PLATE		208020G01	1	1	1	
		(240NE-21)	208484G01	-	1	1	
3	TRUSS HEAD TAPPING SCREW T2		FT20406M0	3	3	3	
	TRUSS HEAD SCREW	(240NE-21)	FST0408S0	-	3	3	
4	WATER PAN HANGER		3H2059-01	2	2	2	
5	TRUSS HEAD TAPPING SCREW T2		FT20416M0	4	4	4	
	TRUSS HEAD MACHINE SCREW	(240NE-21)	FST0420S0	-	4	4	
6	TRUSS HEAD TAPPING SCREW T2		FT20425M0	4	4	4	
	TRUSS HEAD SCREW	(240NE-21)	FST0425S0	-	4	4	
7	BRACKET		402957-01	2	2	2	
8	SCREW SPRING HOOK		4H2582G01	2	2	2	
9	PUMP MOTOR	PMX-352BHZ1S	P02715-01	1	1	1	
10	BRACKET - PUMP		4Y6617M01	1	1	1	
11	HEX HEAD BOLT		FBK0412S0	4	4	4	
	(SPRING WASHER AND FLAT WASHER)						
12	FLANGE NUT		FNHF04S0	4	4	4	
13	TUBE - SILICONE		4Y7388Z02	1	1	1	
14	NYLON TIE	CV-100	7920-0002	2	2	2	
15	TRUSS HEAD TAPPING SCREW T2		FT20516M0	2	2	2	
	TRUSS HEAD SCREW	(240NE-21)	FST0516S0	-	2	2	
16	SUCTION TUBE		4Y6641R01	1	1	1	
17	DISCHARGE TUBE		4Y6642R01	1	1	1	
18	PIPE - DRAIN		315530-01	1	1	1	
19	TRUSS HEAD MACHINE SCREW		FST0410S0	1	1	1	
20	O-RING		7611-G025	1	1	1	
21	NUT	(240NE-21)	FNH104S0	-	4	4	

IM-240NE(-21,-23)
IM-240WNE(-23)

L. BIN SWITCH ASSY

(A-1) and later

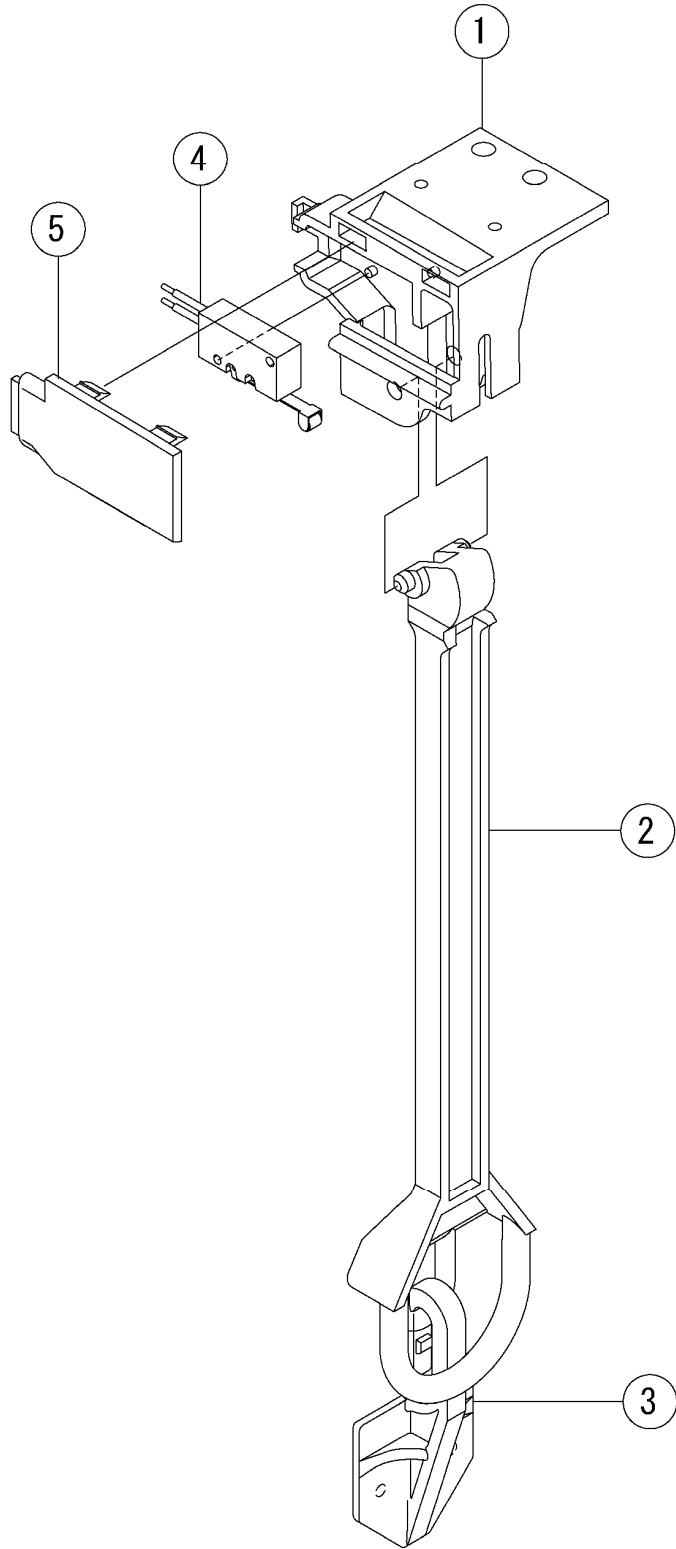

HE,GRAM

MODEL: IM-240NE,-21,-23 IM-240WNE,-23				TITLE: L.BIN SWITCH AY			
INDEX NO.	DESCRIPTION	MATERIAL OR MODEL NUMBER	PART NUMBER	REQ'D NUMBER			
				A-1,B-0 B-1	B-2 B-3	B-4,C-0 D-0,E-0	
1	SWICH BOX		2H2043-01	1	1	1	
2	SWITCH ACTUATOR		3H1369-02	1	1	1	
3	DETECTOR		311044-01	1	1	1	
4	MICRO SWITCH		456432-02	1	1	1	
5	SWITCH BOX COVER		4H8785-01	1	1	1	

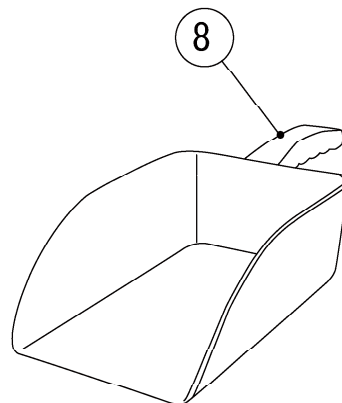
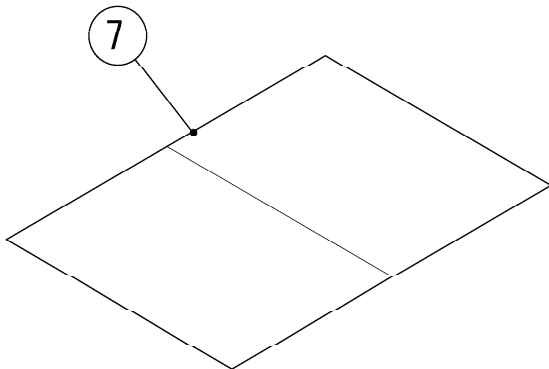
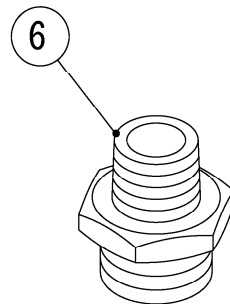
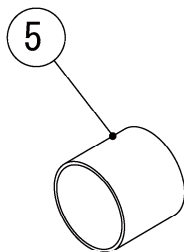
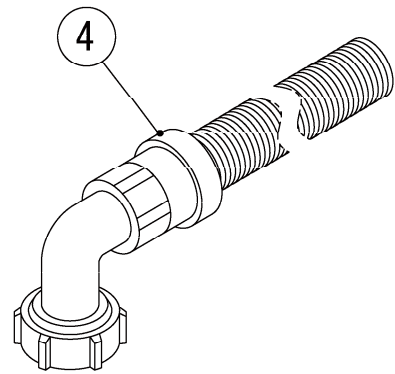
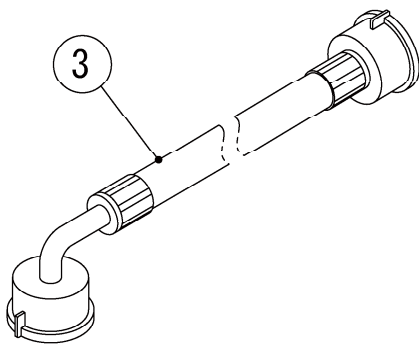
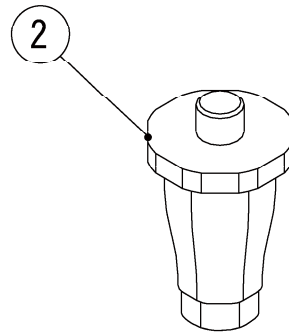
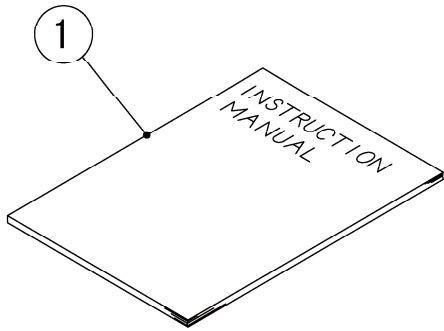

HE,GRAM

MODEL: IM-240NE,-21,-23 IM-240WNE,-23				TITLE: M.ACCESSORIES			
INDEX NO.	DESCRIPTION	MATERIAL OR MODEL NUMBER	PART NUMBER	REQ'D NUMBER			
				A-1,B-0 B-1	B-2 B-3	B-4,C-0 D-0,E-0	
1	INSTRUCTION MANUAL		L1E1EC201	1	1	1	
2	LEG	SDKO-90H-NS⇒SDKO-90HE-NS	446729-01	4	4	4	
3	INLET HOSE	(240NE,-21,-23)	P03534-01	1	1	1	
		(240WNE,-23)		2	2	2	
4	OUTLET HOSE	(240NE,-21,-23)	452365-01	1	1	1	
		(240WNE,-23)		2	2	2	
5	CAP		417323-01	1	1	1	
6	ADAPTOR	(240WNE,-23)	450724-01	2	2	2	
7	INSTRUCTION SHEET		121594L01	1	1	1	
8	SCOOP		P00315-01	1	1	1	