

No.	F087-3784
ISSUED:	Dec. 27, 2012
REVISED:	Dec. 14, 2015



HOSHIZAKI
SELF-CONTAINED FLAKER

MODEL FM-480AKE-HC(-SB)
FM-480AKE-HCN(-SB)

(F087, F087-C101, F087-C106, F087-C107)

PARTS LIST
(HE)

B-1 DEC. 2012
C-0 JAN. 2013
D-0 JAN. 2014
D-1 JAN. 2014
E-0 JAN. 2015
E-2 SEP. 2015

List of Specifications

FM-480AKE-HC	F087	
FM-480AKE-HC-SB	F087-C101	Chasiss : SUS304
FM-480AKE-HCN	F087-C106	Nugget type
FM-480AKE-HCN-SB	F087-C107	Nugget type, Chasiss : SUS304

Auxiliary Codes

Auxiliary Code Breakdown

The auxiliary code is the first two characters in the serial number. The first character indicates the year. Years progress or regress in alphabetical order. The series runs from "A" through "V" and the letters "I" and "O" are skipped. The second character indicates significant part changes within a year. Base is "0" and this number advances for each change. In cases where there is a letter in parentheses, this designates the month. This is the last character in the serial number. The series runs from "(A)" through "(M)" and the letter "(I)" is skipped. This designation is only included when identifying a parts change within an auxiliary code.

Note About Ordering Parts

Most assemblies cannot be ordered as complete units; parts in the assemblies generally must be ordered separately.

FASTENER PART NUMBER

SCREWS

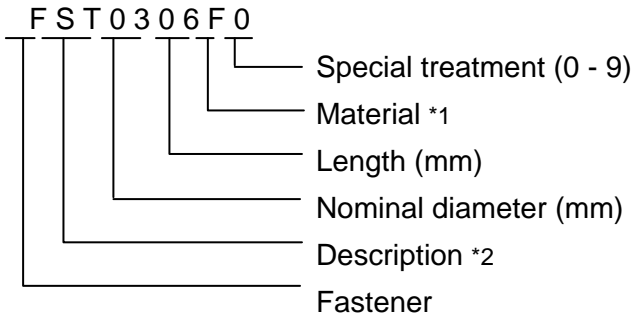

*1 **Material**

- F: Steel
- S: Austenitic stainless steel
- M: Martensitic stainless steel
- B: Copper alloy
- P: Polycarbonate
- N: Polyamide
- V: PVC
- A: ABS
- X: Polyacetal

NUTS & WASHERS

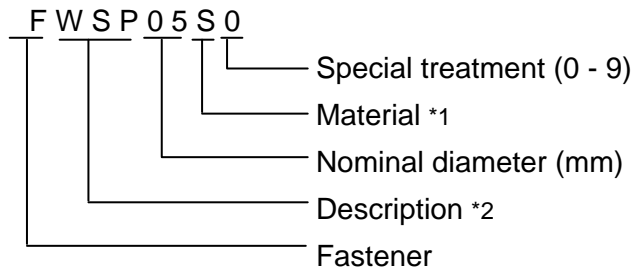

*2 **Description**

- First letter
- S: Machine screw
- T: Tapping screw
- M: Wood screw
- B: Bolt
- W: Washer
- N: Nut

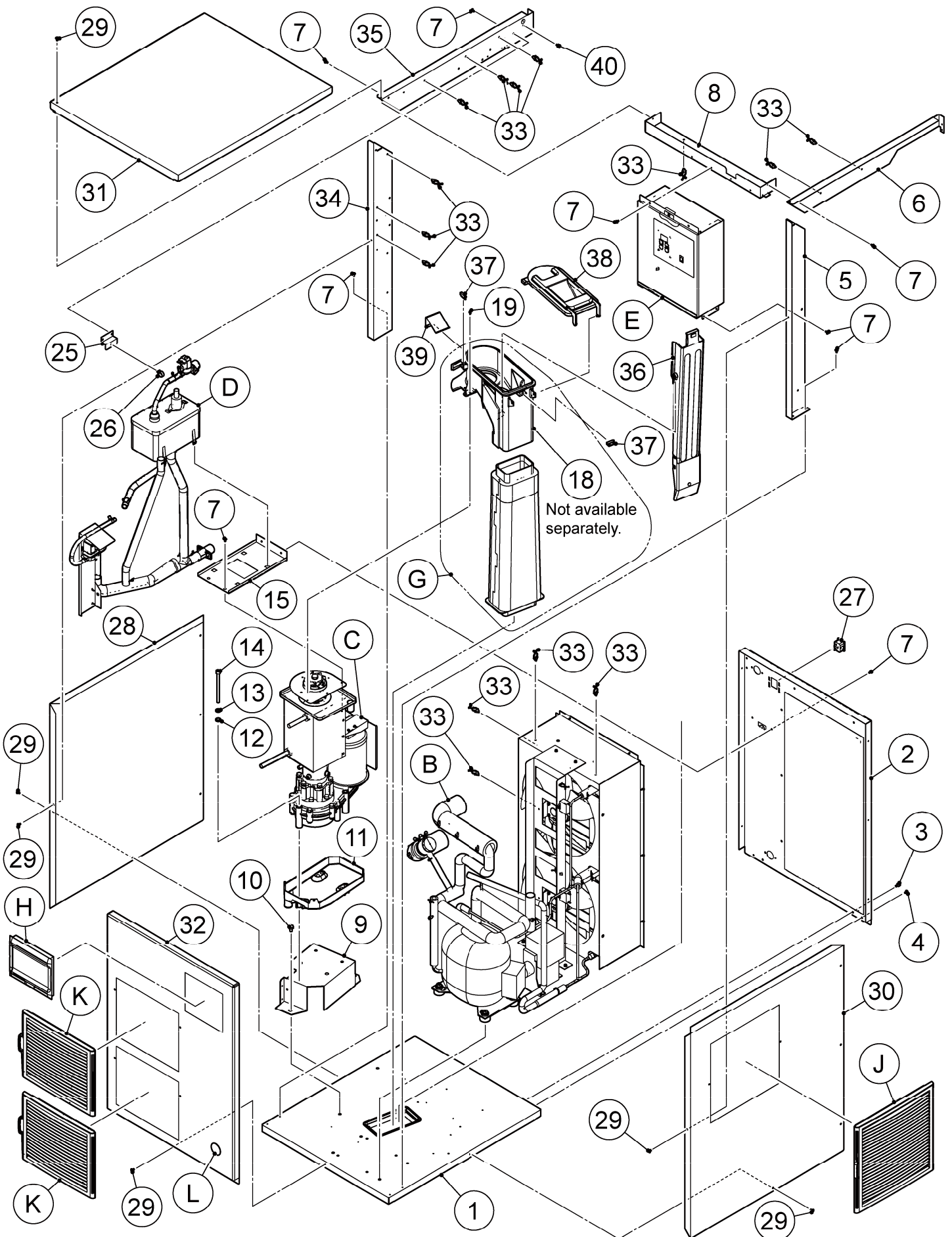

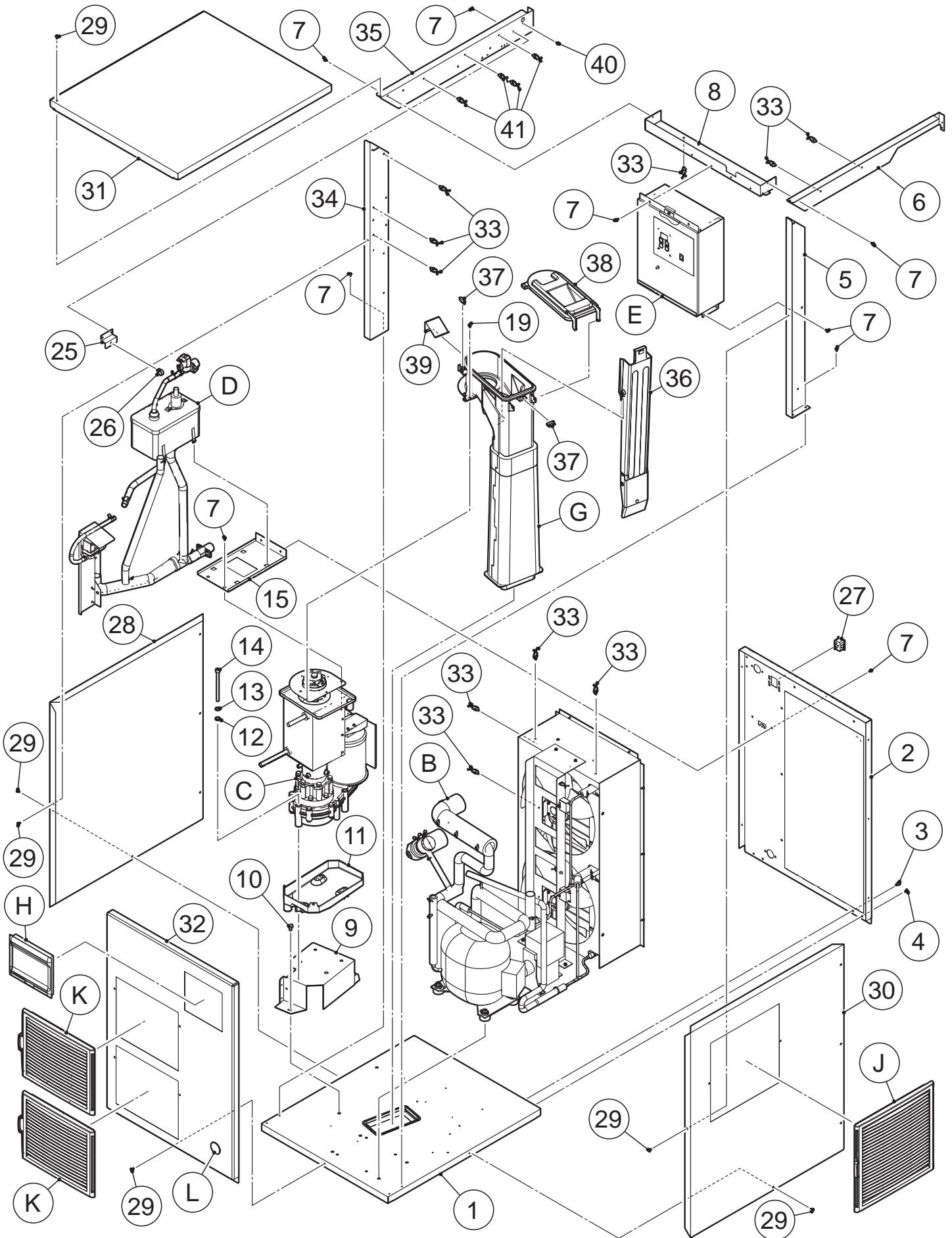

HE

MODEL: FM-480AKE-HC(-SB)		TITLE: A. ICE FLAKER ASSY							
FM-480AKE-HCN(-SB)									
INDEX NO.	DESCRIPTION	MATERIAL OR MODEL NUMBER	PART NUMBER	REQ'D NUMBER					
				B-1 D-0	D-1 E-1	E-2			
B	REFRIGERATION CIRCUIT		122277A01	1	-	-			
			122462A01	-	1	1			
C	ICE MAKING UNIT		377281A01	1	-	-			
			377777A01	-	1	1			
		NUGGET	377281001	1	-	-			
		F087-C106	377777001	-	1	1			
		NUGGET, SUS304 F087-C107		-	1	1			
D	WATER CIRCUIT		122281A01	1	-	-			
			122460A01	-	1	1			
E	CONTROL BOX ASSY		263387A01	1	1	1			
F	BAND (A) ASSY		348911A01	1	-	-			
G	CHUTE ASSY		113006A01	1	-	-			
			Integrated with 18.SPOUT - 70 Not available separately. Order G.SPOUT ASSY - CHUTE 70 (268065A02)	-	1	-			
	SPOUT ASSY - CHUTE 70		268065A02	-	-	1			
H	WINDW PANEL ASSY		348243A03	1	1	1			
J	LOUVER ASSY		377439A01	1	1	1			
K	LOUVER ASSY		3Y6179A01	2	2	2			
L	LABEL LOCATION		263408A01	1	1	1			
			F087-C106	263408A02	1	1	1		
			F087-C101	263408A05	-	1	1		
			F087-C107	263408A06	-	1	1		
P	ACCESSORIES		A02655-01	1	1	1			
1	CHASSIS		263384G01	1	-	-			
			264129G01	-	1	1			
			SUS304 F087-C101, F087-C107	266086G01	-	1	1		
2	REAR PANEL (A)		377279G01	1	1	1			
3	HEX HEAD BOLT (SPRING WASHER AND FLAT WASHER)		FBK0512S0	2	2	2			
4	T2 TRUSS HEAD SCREW		FT20408F0	2	2	2			
5	SIDE FRAME(R1)		264225M01	1	1	1			
6	SIDE FRAME(R2)		264226M01	1	1	1			

HE

MODEL: FM-480AKE-HC(-SB)		TITLE: A. ICE FLAKER ASSY						
FM-480AKE-HCN(-SB)								
INDEX NO.	DESCRIPTION	MATERIAL OR MODEL NUMBER	PART NUMBER	REQ'D NUMBER				
				B-1 D-0	D-1 E-1	E-2		
7	TRUSS HEAD SCREW		FST0408F0	21	21	21		
8	FRONT FRAME		261984M01	1	1	1		
9	BRACKET - GEAR MOTOR		373520G01	1	-	-		
			374371G01	-	1	1		
10	HEX HEAD BOLT		FBH0812F0	3	3	3		
11	DRAIN PAN		261640P01	1	1	1		
12	SEAL WASHER		458299-01	3	3	3		
13	SPRING WASHER		FWSP08S0	3	3	3		
14	HEXAGON SOCKET HEAD CAP SCREW		461285-01	3	3	3		
15	BRACKET - RESERVOIR		377282M01	1	-	-		
			378076M01	-	1	1		
16	RING		432661-02	1	-	-		
17	O - RING		7616-G070	1	-	-		
18	SPOUT		104797-01	1	-	-		
	SPOUT - 70	Integrated with CHUTE Not available separately. Order SPOUT - CHUTE 70 (268064G02)		-	1	-		
19	HEX HEAD BOLT (SPRING WASHER AND FLAT WASHER)		FBK0408S0	3	-	-		
			FBK0412S0	-	3	3		
20	PACKING		454256-01	1	-	-		
21	BAND (B)		459995G01	1	-	-		
22	FLANGE NUT		FNHF06S0	3	-	-		
23	NUT		FNH106F0	5	-	-		
24	DRIP GUIDE		350725-01	1	-	-		
25	BRACKET - WATER SUPPLY		477660M01	1	1	1		
26	CLAMP		428644-03	1	1	1		
27	CONNECTOR		P00246-01	1	1	1		
28	SIDE PANEL (L)		261989M01	1	1	1		
29	TRUSS HEAD SCREW		FST0408S0	12	12	12		
30	SIDE PANEL (R)		263238M01	1	1	1		
31	TOP PANEL		261991M01	1	1	1		
32	FRONT PANEL		122275G01	1	1	1		
33	CLAMP	No.249	427902-03	14	14	10		
34	SIDE FRAME (L1)		264214M01	1	1	1		
35	SIDE FRAME (L2)		264215M01	1	1	1		

HE

MODEL: FM-480AKE-HC(-SB)		TITLE: A. ICE FLAKER ASSY						
FM-480AKE-HCN(-SB)								
INDEX NO.	DESCRIPTION	MATERIAL OR MODEL NUMBER	PART NUMBER	REQ'D NUMBER				
				B-1 D-0	D-1 E-1	E-2		
36	ACTUATOR		382184G02	-	1	1		
		F087-C106, F087-C107	382184G01	-	1	1		
37	REED SWITCH		P02940-01	-	2	2		
38	SPOUT COVER - 70		263887G01	-	1	1		
39	SPRING - SPOUT		478013M01	-	1	1		
40	PAN HEAD SCREW SW		FSK0408S0	-	1	1		
41	CLAMP	No.2674	427902-02	-	-	4		

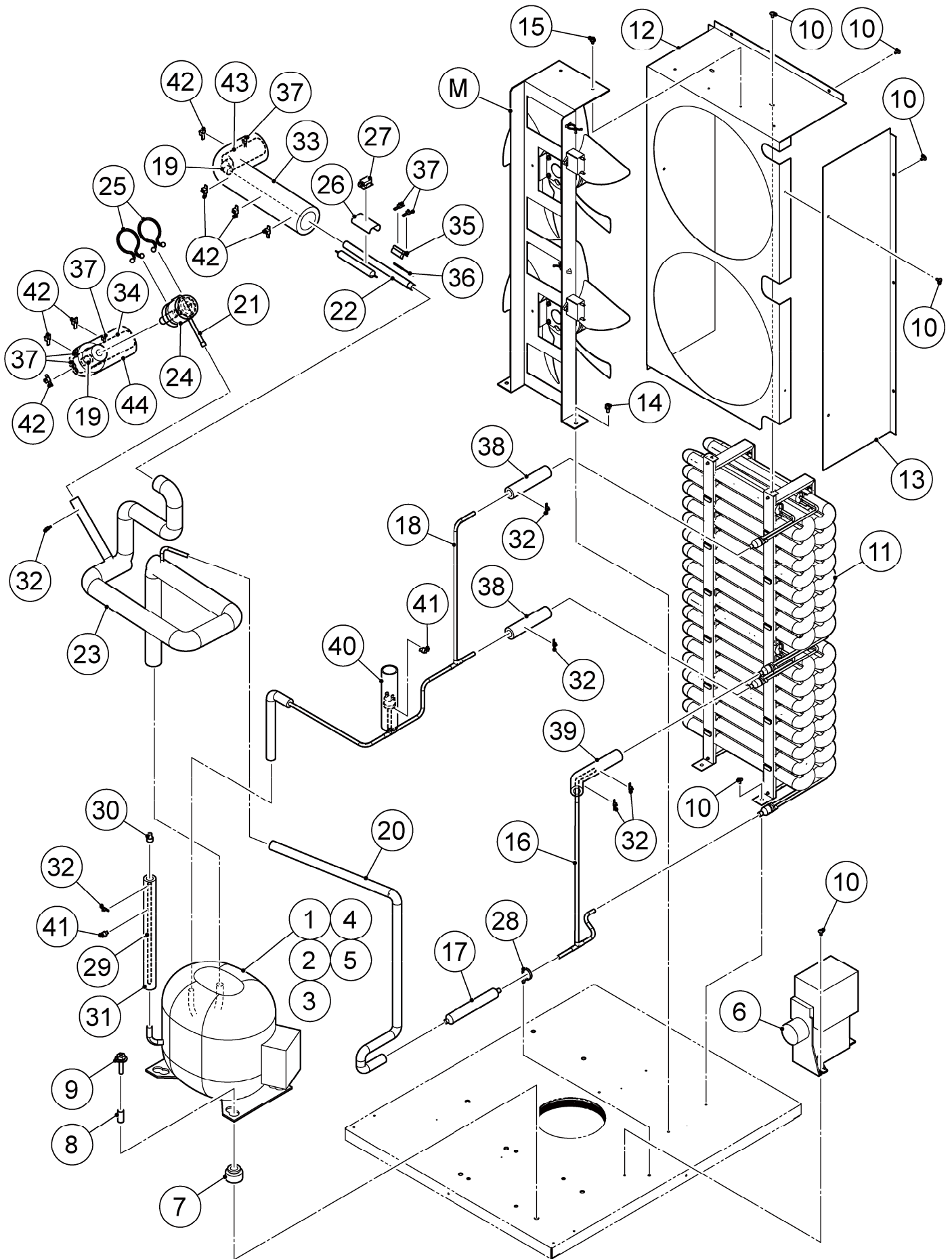

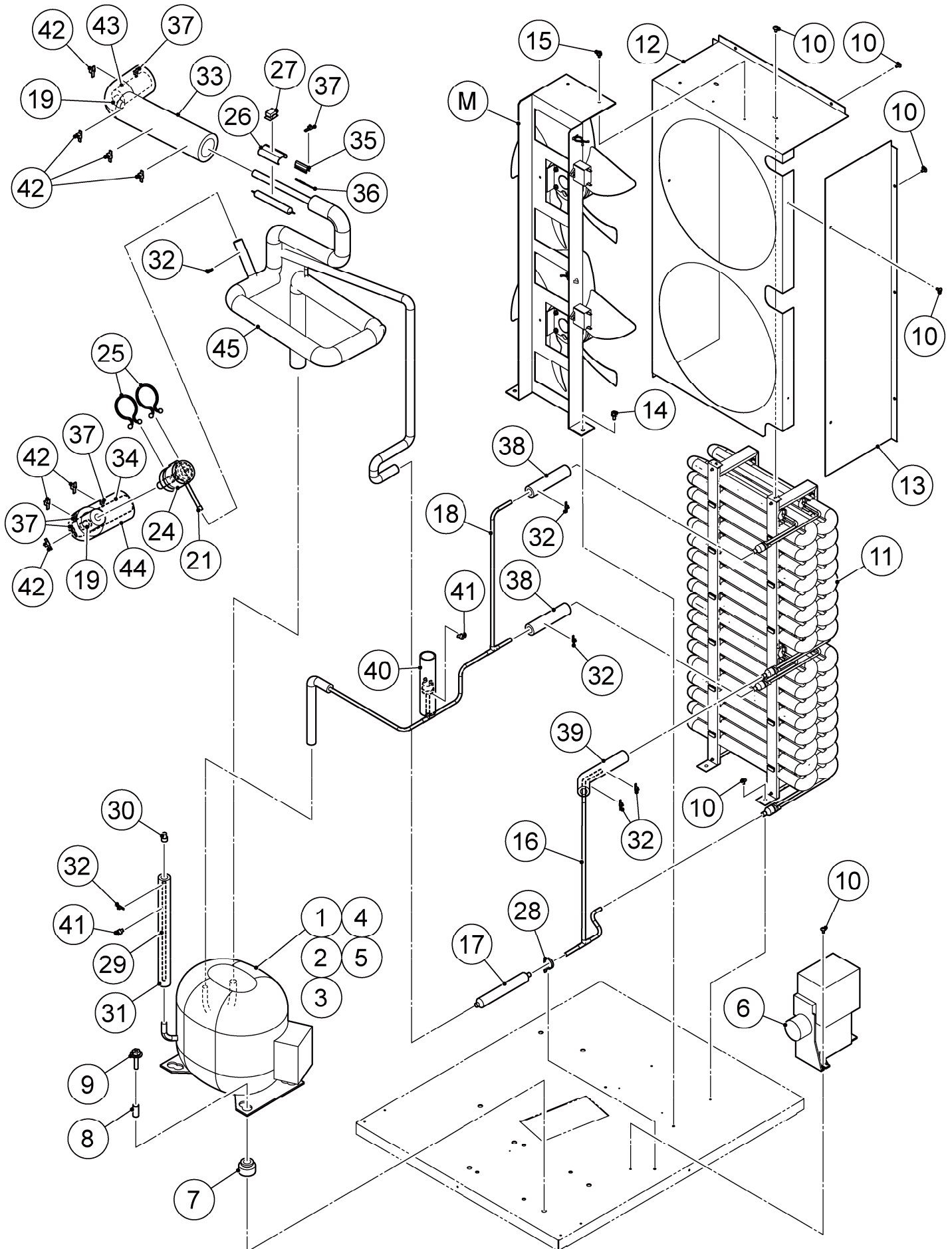

HE

MODEL: FM-480AKE-HC(-SB)		TITLE: B. REFRIGERATION CIRCUIT						
FM-480AKE-HCN(-SB)								
INDEX NO.	DESCRIPTION	MATERIAL OR MODEL NUMBER	PART NUMBER	REQ'D NUMBER				
				B-1 D-0	D-1 E-1	E-2		
M	FAN MOTOR ASSY		263389A01	1	1	1		
1	COMPRESSOR		P02820-01	1	1	1		
2	PROTECTOR RETAINER		P02815-01	1	1	1		
3	SCREW		P00840-01	1	1	1		
4	TERMINAL COVER		P02814-01	1	1	1		
5	PROTECTOR		P02821-01	1	1	1		
6	BOX WITH ELECTRICAL COMPONENTS		P02822-01	1	1	1		
7	GROMMET		P00846-01	4	4	4		
8	SPACER		P00847-01	4	4	4		
9	BOLT		436206-03	4	4	4		
10	TRUSS HEAD SCREW		FST0408F0	16	16	16		
11	CONDENSER ASSY		258069G02	1	1	1		
12	SHROUD - B		263388M01	1	1	1		
13	SHROUD - A		377283M01	1	1	1		
14	HEX HEAD BOLT (SPRING WASHER AND FLAT WASHER)		FBK0512S0	2	2	2		
15	HEX HEAD BOLT (SPRING WASHER AND FLAT WASHER)		FBK0408S0	2	2	2		
16	COPPER TUBE (A) - H		377286G01	1	1	1		
17	DRIER		462813-01	1	1	1		
18	COPPER TUBE B - H		263400G01	1	1	1		
19	ELBOW		417395-03	2	2	2		
20	COPPER TUBE(C) - H		377305G01	1	-	-		
21	EXPANSION VALVE		P01626-01	1	1	1		
22	COPPER TUBE(A) - L		477689M01	1	-	-		
23	HEAT EXCHANGER		263404G01	1	-	-		
24	VALVE COVER		3Y3196P01	1	1	1		
25	CLAMP		P00752-01	2	2	2		
26	HOLDER - EXP. VALVE 1/2		3A0112-01	1	1	1		
27	CLAMP		443461-01	1	1	1		
28	PUSH MOUNT TIE		436156-01	1	1	1		
29	COPPER TUBE(C) - L		477693M01	1	1	1		
30	LOCKRING STOPPER		P01677-01	1	1	1		
31	INSULATION TUBE		H71323250	1	1	1		

HE

MODEL: FM-480AKE-HC(-SB)		TITLE: B. REFRIGERATION CIRCUIT						
FM-480AKE-HCN(-SB)								
INDEX NO.	DESCRIPTION	MATERIAL OR MODEL NUMBER	PART NUMBER	REQ'D NUMBER				
				B-1 D-0	D-1 E-1	E-2		
32	TIE	CV-100	7920-0002	6	6	6		
33	INSULATION TUBE		H73858B30	1	1	1		
34	INSULATION TUBE		H71333B22	1	1	1		
35	HOLDER - THERMISTOR		427430-01	1	-	-		
			458132-01	-	1	1		
36	THERMISTOR ASSY		475407G01	1	1	1		
37	TIE		7920-0003	6	5	5		
38	INSULATION TUBE		H71323B10	2	2	2		
39	INSULATION TUBE		H71323B15	1	1	1		
40	INSULATION TUBE		H71323130	1	1	1		
41	NYLON TIE	CV-200	7920-0010	2	2	2		
42	NYLON TIE	CV-250	7920-0011	7	7	7		
43	INSULATION TUBE		H71333B10	1	1	1		
44	INSULATION TUBE		H73858B22	1	1	1		
45	COPPER TUBE - L		264531G01	-	1	1		

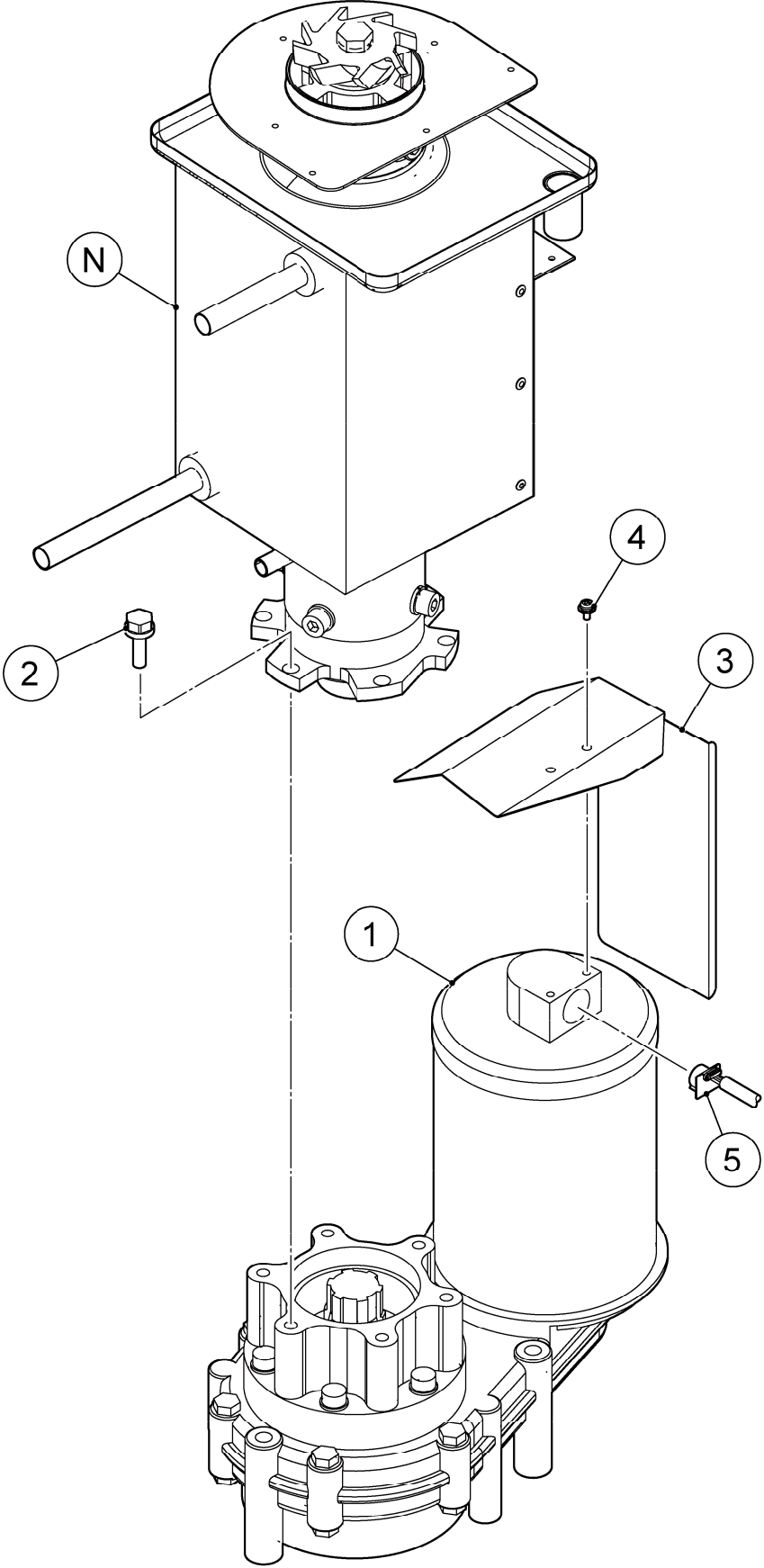

HE

MODEL: FM-480AKE-HC(-SB)		TITLE: C. ICE MAKING UNIT						
FM-480AKE-HCN(-SB)								
INDEX NO.	DESCRIPTION	MATERIAL OR MODEL NUMBER	PART NUMBER	REQ'D NUMBER				
				B-1 D-0	D-1 E-1	E-2		
N	EVAPORATOR ASSY		263386A01	1	-	-		
			264133A01	-	1	1		
		NUGGET F087-C106	263386001	1	-	-		
		NUGGET, SUS304 F087-C107	264133001	-	1	1		
1	GEAR MOTOR		466223-01	1	1	1		
2	HEX.HEAD BOLT W/WASHER (SW)		461888-01	6	6	6		
3	COVER - GEAR MOTOR		377280M01	1	1	1		
4	PAN HEAD SCREW SW		FSK0408S0	2	2	2		
5	ROTATION SENSOR	GEAR MOTOR ACCESSORY	459861-03	1	1	1		

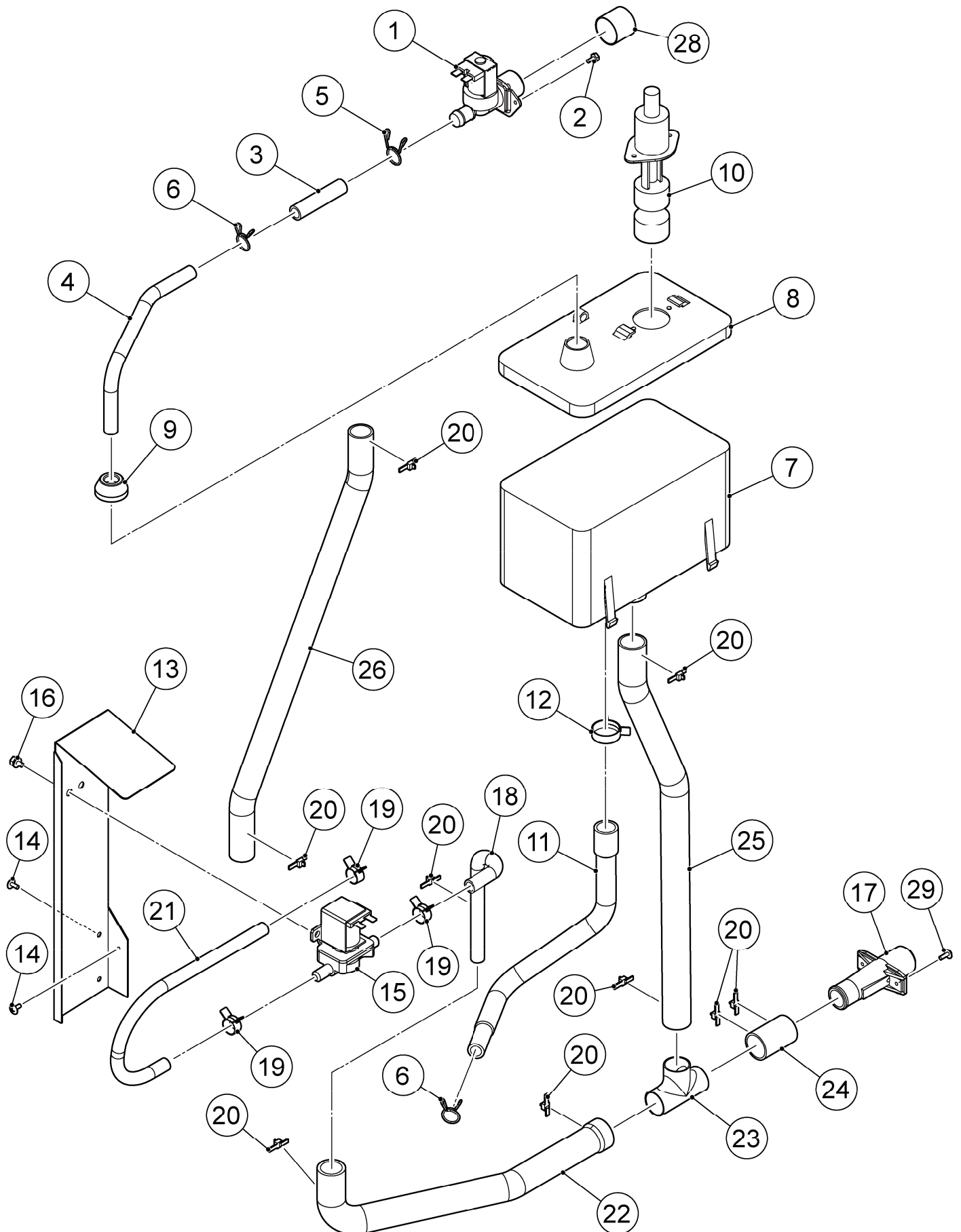

HE

MODEL: FM-480AKE-HC(-SB)		TITLE: D. WATER CIRCUIT						
FM-480AKE-HCN(-SB)								
INDEX NO.	DESCRIPTION	MATERIAL OR MODEL NUMBER	PART NUMBER	REQ'D NUMBER				
				B-1 D-0	D-1 E-1	E-2		
1	WATER VALVE		452993-01	1	1	1		
2	HEX HEAD BOLT		FBH0408S0	2	2	2		
3	SILICONE HOSE		4Y6912R06	1	1	1		
4	PIPE - WATER SUPPLY		477694M01	1	-	-		
			478323M01	-	1	1		
5	HOSE CLAMP		435934-03	1	1	1		
6	HOSE CLAMP		435934-02	2	2	2		
7	RESERVOIR		232626-01	1	1	1		
8	COVER - RESERVOIR		232627-01	1	1	1		
9	COVER - RESERVOIR INLET		415094-01	1	1	1		
10	FLOAT SWITCH		458279-01	1	1	1		
11	HOSE (A)		373517P01	1	1	1		
12	CLIP BAND		423866-08	1	1	1		
13	BRACKET - VALVE		373530M01	1	1	1		
14	TRUSS HEAD SCREW		FST0408F0	3	3	3		
15	WATER VALVE		468655-01	1	1	1		
16	HEX HEAD BOLT (SPRING WASHER AND FLAT WASHER)		FBK0508S0	2	2	2		
17	DRAIN PIPE		321035-01	1	1	1		
18	DRAIN HOSE (B)		459329-01	1	1	1		
19	CLAMP		423866-03	3	3	3		
20	TIE	CV-150	7920-0003	9	7	7		
21	PVC Hose (Food Grade)		HD0912300	1	1	1		
22	HOSE (B)		373516P01	1	1	1		
23	TEE		122281M01	1	-	-		
			122460M01	-	1	1		
24	PVC Hose (Food Grade)		HD2226040	1	-	-		
			HD2226060	-	1	1		
25	PVC Hose (Food Grade)		HD2226460	1	-	-		
			HD1923490	-	1	1		
26	PVC Hose (Food Grade)		HD1923460	1	1	1		
28	CAP		417323-01	1	1	1		
29	TRUSS HEAD TAPPING SCREW T2		FT20410S0	2	2	2		

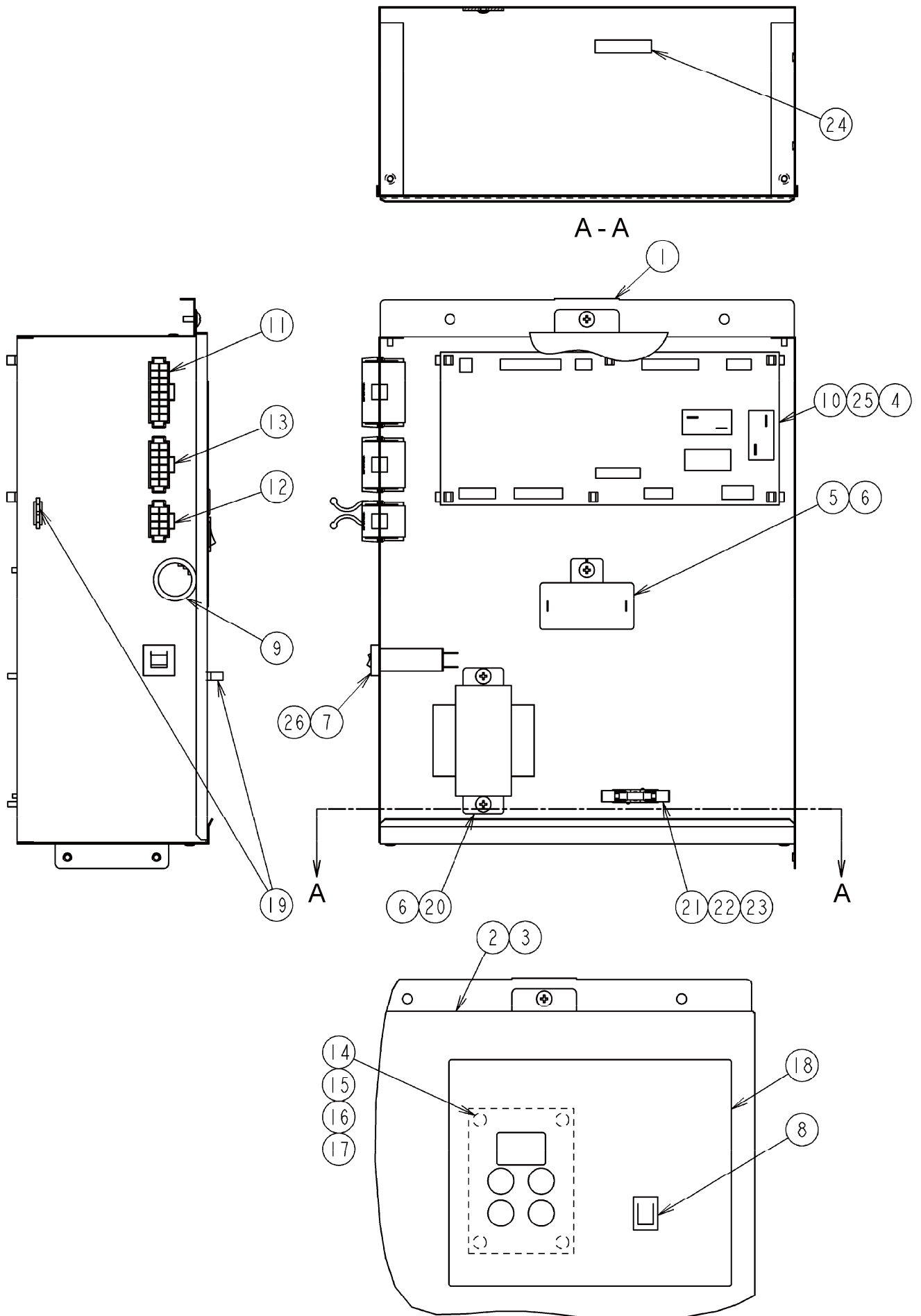

HE

MODEL: FM-480AKE-HC(-SB)		TITLE: E. CONTROL BOX ASSY						
FM-480AKE-HCN(-SB)								
INDEX NO.	DESCRIPTION	MATERIAL OR MODEL NUMBER	PART NUMBER	REQ'D NUMBER				
				B-1 D-0	D-1 E-1	E-2		
1	CONTROL BOX		122276G01	1	1	1		
2	COVER - CONTROL BOX		376330G01	1	1	1		
3	TRUSS HEAD SCREW		FST0408F0	1	1	1		
4	BOARD SUPPORT		414929-01	6	6	6		
5	CAPACITOR		459704-01	1	1	1		
6	T2 TRUSS HEAD SCREW		FT20408F0	3	3	3		
7	PROTECTOR		440972-07	1	1	1		
8	ROCKER SWITCH		460681-01	1	1	1		
9	BUSHING		428394-05	1	1	1		
10	CONTROLLER BOARD - 09CM		P01372-18	1	1	1		
11	HARNESS (A)		376352G01	1	1	1		
12	HARNESS (B)		473845G01	1	1	1		
13	HARNESS (C)		374366G01	1	1	1		
14	SPACER		451658-05	4	4	4		
15	OPERATION BOARD - 09CM		P01373-01	1	1	1		
16	FLAT WASHER		FWPL03P0	4	4	4		
17	NUT		FNH103F0	4	4	4		
18	CONTROL LABEL		374148L01	1	1	1		
19	WIRE RETAINER	No.249	427902-03	2	2	2		
20	TRANSFORMER		P02623-01	1	1	1		
21	FUSE HOLDER		4Y2547-01	1	1	1		
22	FUSE		451924-02	1	1	1		
23	PAN HEAD TAPPING SCREW T2		FT50308F0	1	1	1		
24	LABEL - FUSE		477494L01	1	1	1		

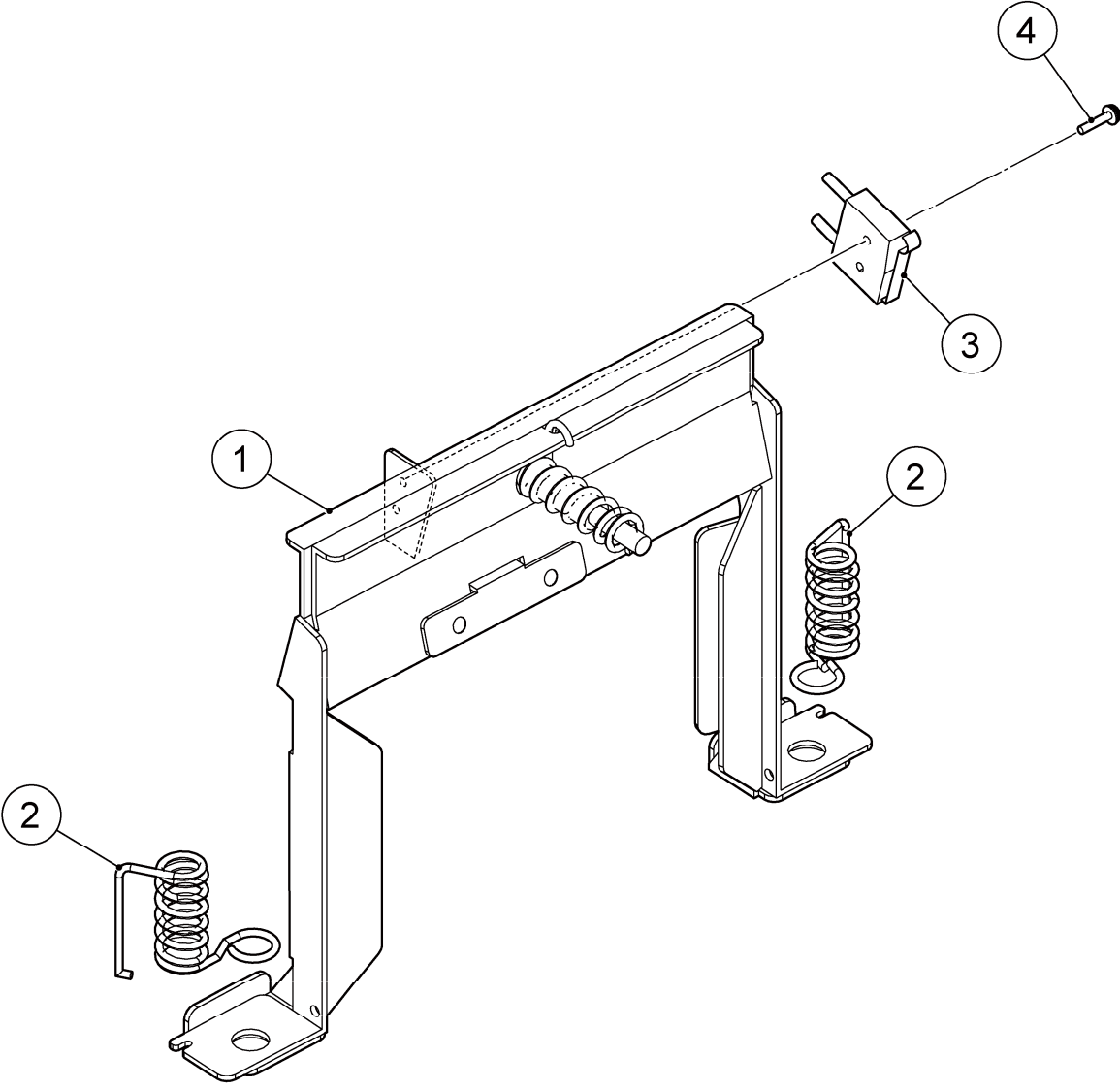

HE

MODEL: FM-480AKE-HC		TITLE: F. BAND (A) ASSY						
FM-480AKE-HCN								
INDEX NO.	DESCRIPTION	MATERIAL OR MODEL NUMBER	PART NUMBER	REQ'D NUMBER				
				B-1				
D-0								
1	BAND (A)		348305G01	1				
2	SPRING (A)		459997-01	2				
3	MICROSWITCH		443992-02	1				
4	PAN HEAD MACHINE SCREW (SPRING WASHER AND FLAT WASHER)		470416-01	2				

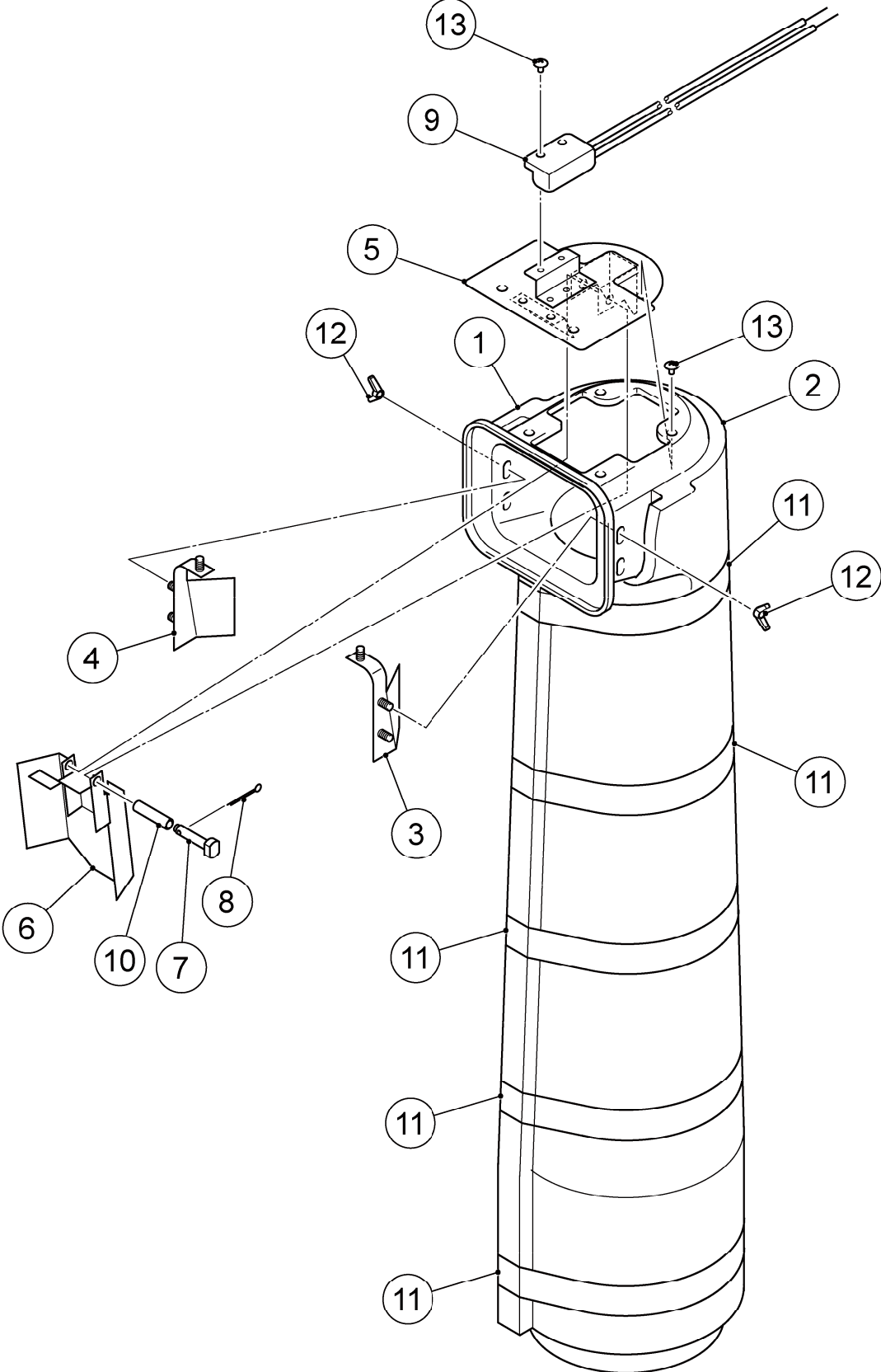

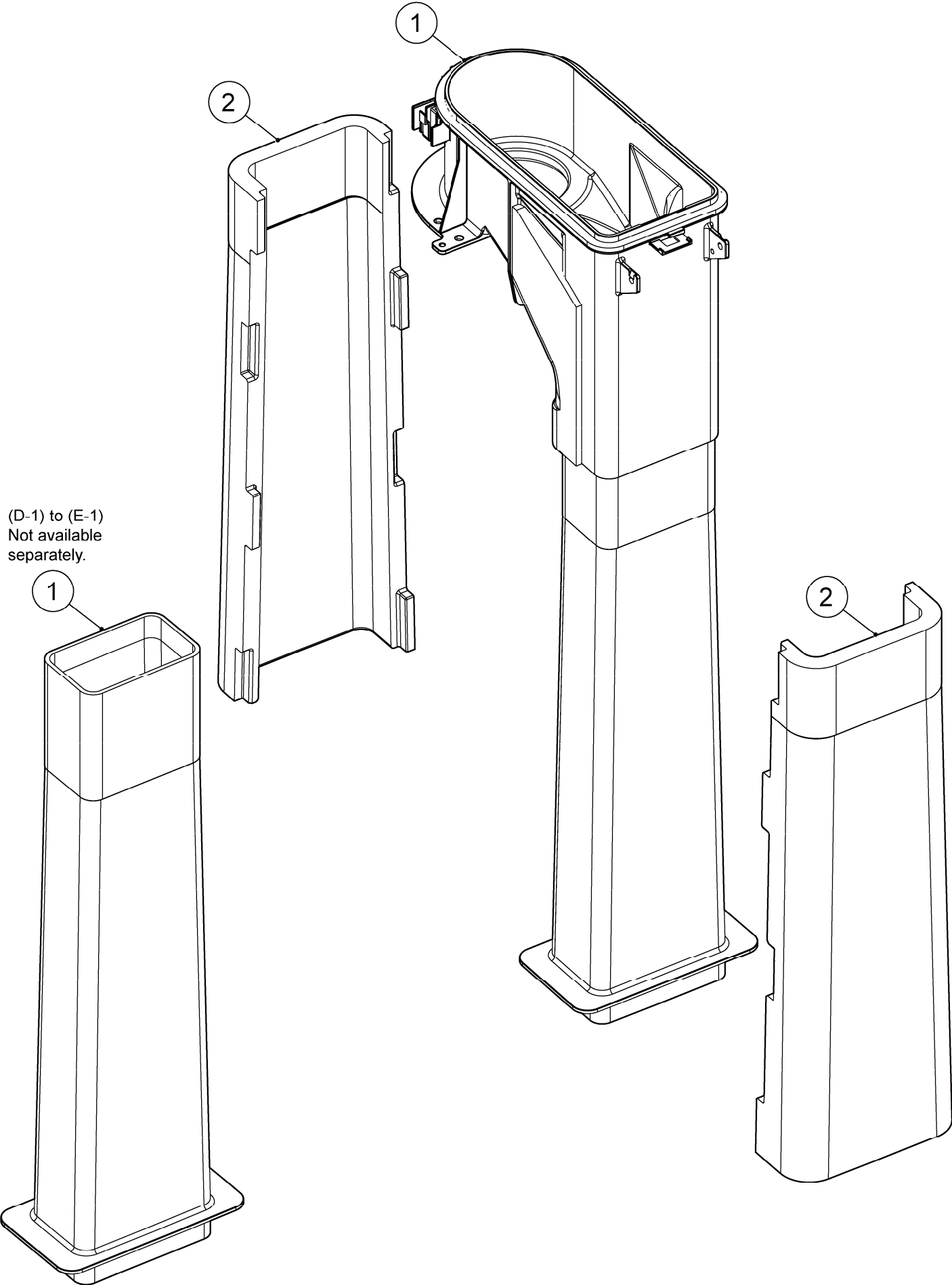

HE

MODEL: FM-480AKE-HC(-SB)		TITLE: G. CHUTE ASSY						
FM-480AKE-HCN(-SB)								
INDEX NO.	DESCRIPTION	MATERIAL OR MODEL NUMBER	PART NUMBER	REQ'D NUMBER				
				B-1 D-0	D-1 E-1	E-2		
1	CHUTE		214823-01	1	-	-		
		Integrated with SPOUT - 70 Not available separately. Order SPOUT - CHUTE 70 (268064G02)		-	1	-		
	SPOUT - CHUTE 70		268064G02	-	-	1		
2	INSULATION - CHUTE		235310-01	1	-	-		
			263903P02	-	2	2		
3	BAFFLE - CHUTE (A)		325122G01	1	-	-		
4	BAFFLE - CHUTE (B)		325123G01	1	-	-		
5	BIN CONTROL		353918G01	1	-	-		
6	ACTUATOR		436848G05	1	-	-		
7	SHAFT		458813-01	1	-	-		
8	SPLIT PIN		711SP1612	1	-	-		
9	PROXIMITY SWITCH		4A2033-01	1	-	-		
10	TUBE		461623-01	1	-	-		
11	TAPE		113006Z01	5	-	-		
12	WING NUT		FNW204S0	6	-	-		
13	TRUSS HEAD SCREW		FST0406S0	4	-	-		

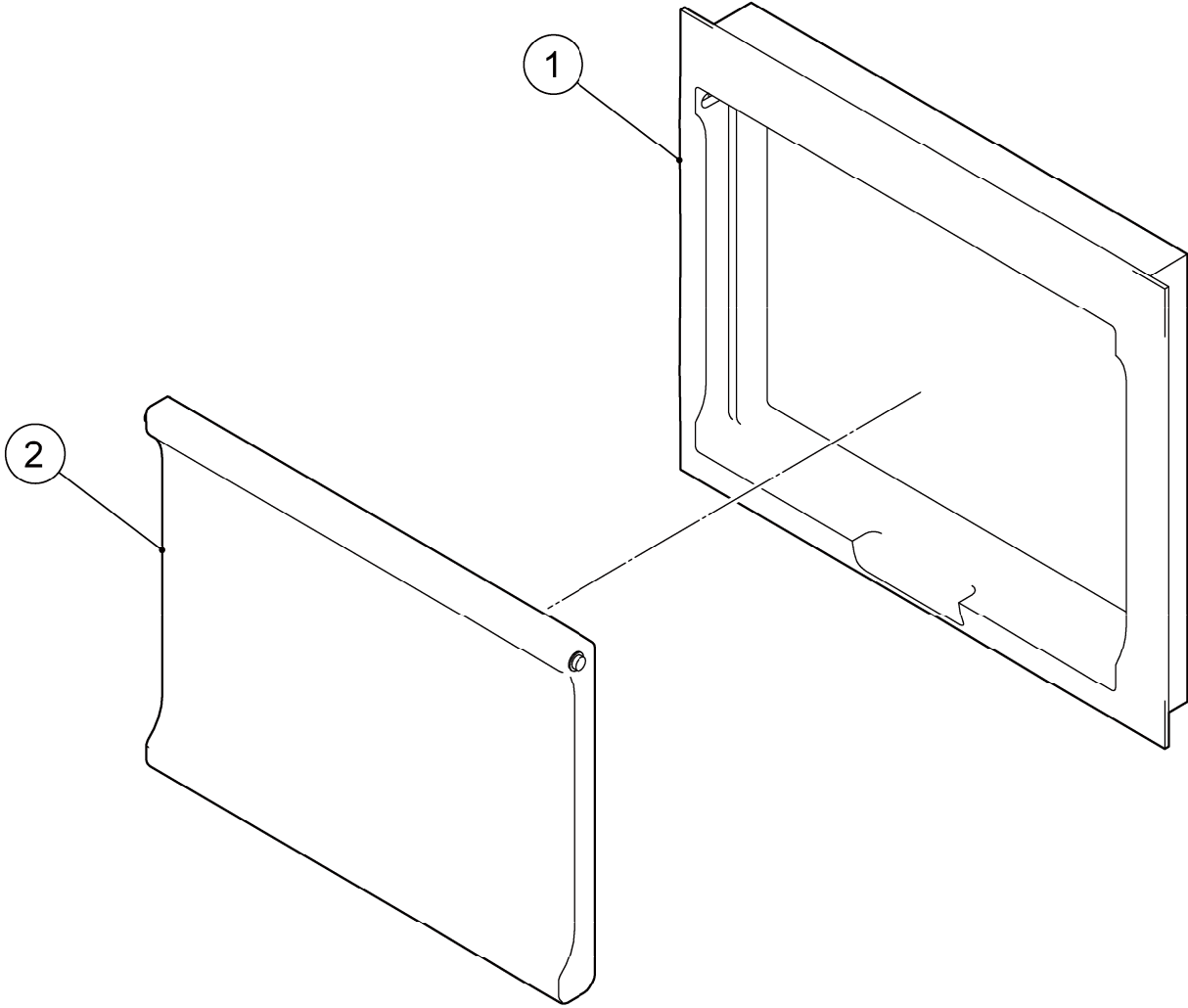

HE

MODEL: FM-480AKE-HC(-SB)		TITLE: H. WINDW PANEL ASSY						
FM-480AKE-HCN(-SB)								
INDEX NO.	DESCRIPTION	MATERIAL OR MODEL NUMBER	PART NUMBER	REQ'D NUMBER				
				B-1 D-0	D-1 E-1	E-2		
1	WIND FRAME		232648-01	1	1	1		
2	WIND PANEL		232649-03	1	1	1		

FM-480AKE-HC(-SB)
FM-480AKE-HCN(-SB)

J. FAN MOTOR ASSY

(B-1) and later

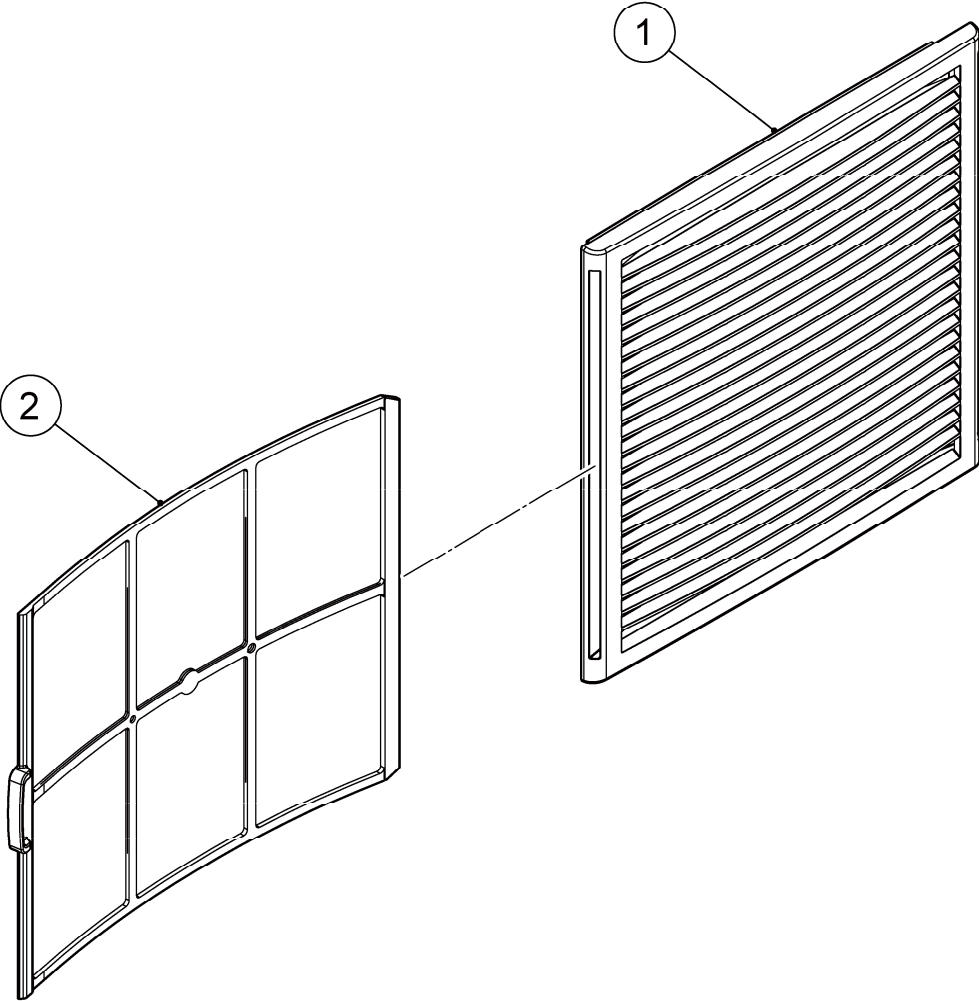

HE

MODEL: FM-480AKE-HC(-SB)		TITLE: J. LOUVER ASSY						
FM-480AKE-HCN(-SB)								
INDEX NO.	DESCRIPTION	MATERIAL OR MODEL NUMBER	PART NUMBER	REQ'D NUMBER				
				B-1 D-0	D-1 E-1	E-2		
1	LOUVER		121931P01	1	1	1		
2	AIR FILTER		262259G01	1	1	1		

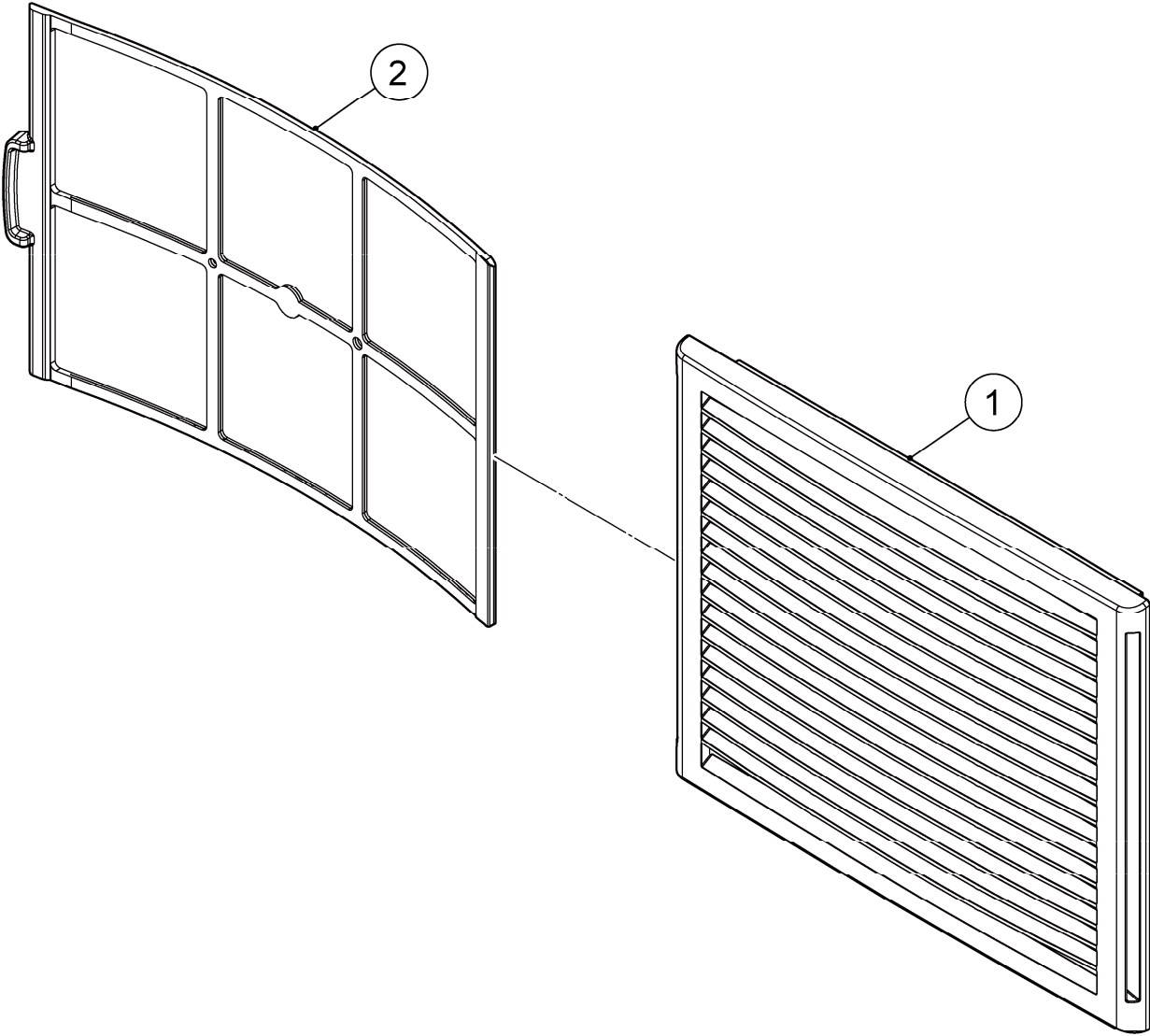

HE

MODEL: FM-480AKE-HC(-SB)		TITLE: K. LOUVER ASSY						
FM-480AKE-HCN(-SB)								
INDEX NO.	DESCRIPTION	MATERIAL OR MODEL NUMBER	PART NUMBER	REQ'D NUMBER				
				B-1 D-0	D-1 E-1	E-2		
1	LOUVER		1H4811P01	1	1	1		
2	AIR FILTER		2X0416G01	1	1	1		

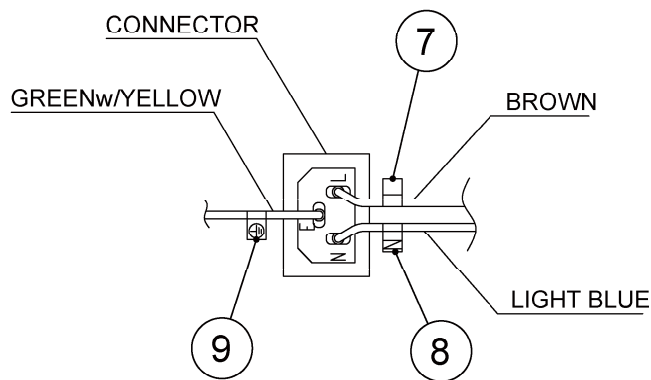
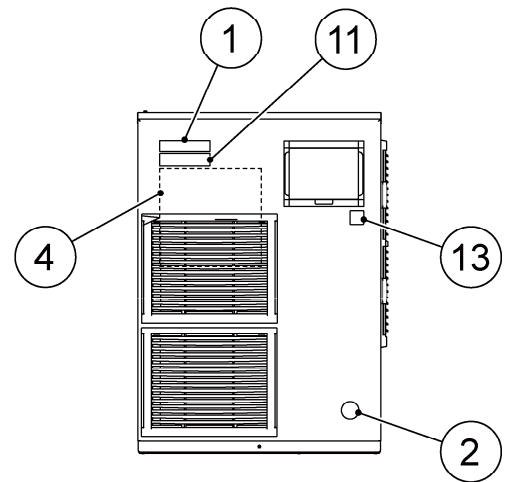
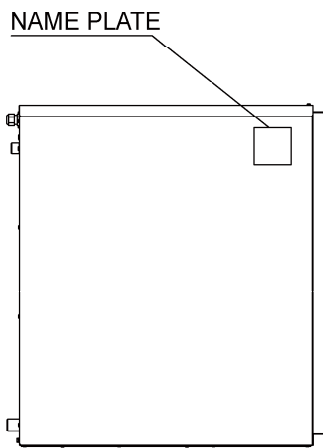
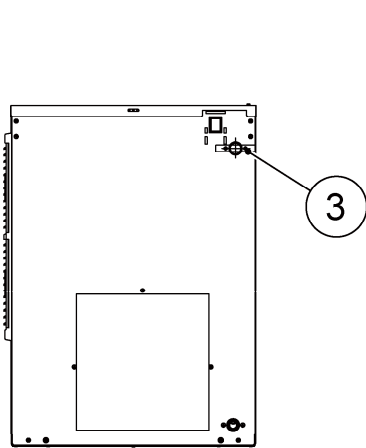
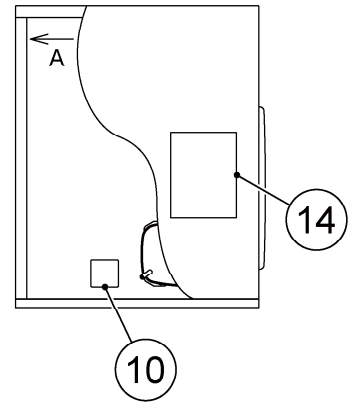
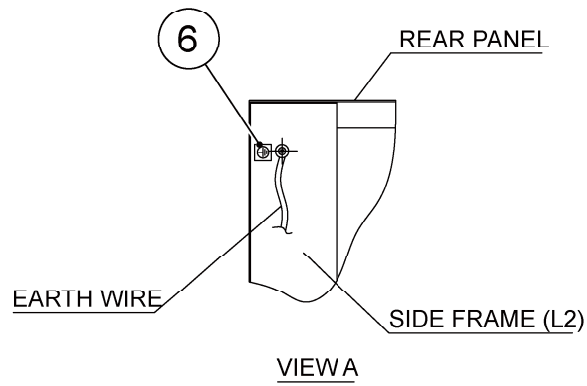

DETAIL LABEL - TERMINAL

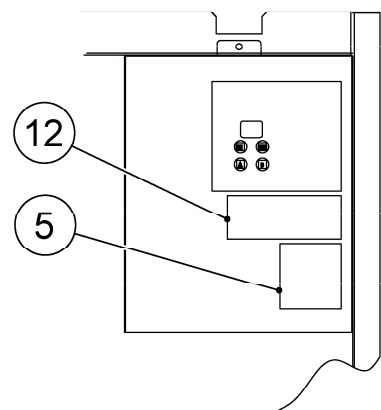

DETAIL CONTROL BOX

HE

MODEL: FM-480AKE-HC(-SB)		TITLE: L. LABEL LOCATION						
FM-480AKE-HCN(-SB)								
INDEX NO.	DESCRIPTION	MATERIAL OR MODEL NUMBER	PART NUMBER	REQ'D NUMBER				
				B-1 D-0	D-1 E-1	E-2		
1	EMBLEM		340842-01	1	1	1		
2	LABEL - PENGUIN		454387-02	1	1	1		
3	CAUTION - LABEL		452552-01	1	1	1		
4	WIRING LABEL		263409L01	1	-	-		
			264598L01	-	1	1		
5	CAUTION LABEL - SERVICE		471180L01	1	1	1		
6	LABEL - GROUND (B)		450452-02	1	-	-		
7	LABEL - TERMINAL		452379-03	1	-	-		
8	LABEL - TERMINAL		452379-04	1	-	-		
9	LABEL - TERMINAL		452379-05	1	-	-		
10	LABEL - R290		474520L01	1	1	1		
11	LABEL - HFCFREE		373508L01	1	1	1		
12	CAUTION LABEL - HYDROCARBON		373722L01	1	1	1		
13	LABEL - HACCP		476519L01	1	1	1		
14	INSTRUCTION SHEET		378049L01	-	1	1		

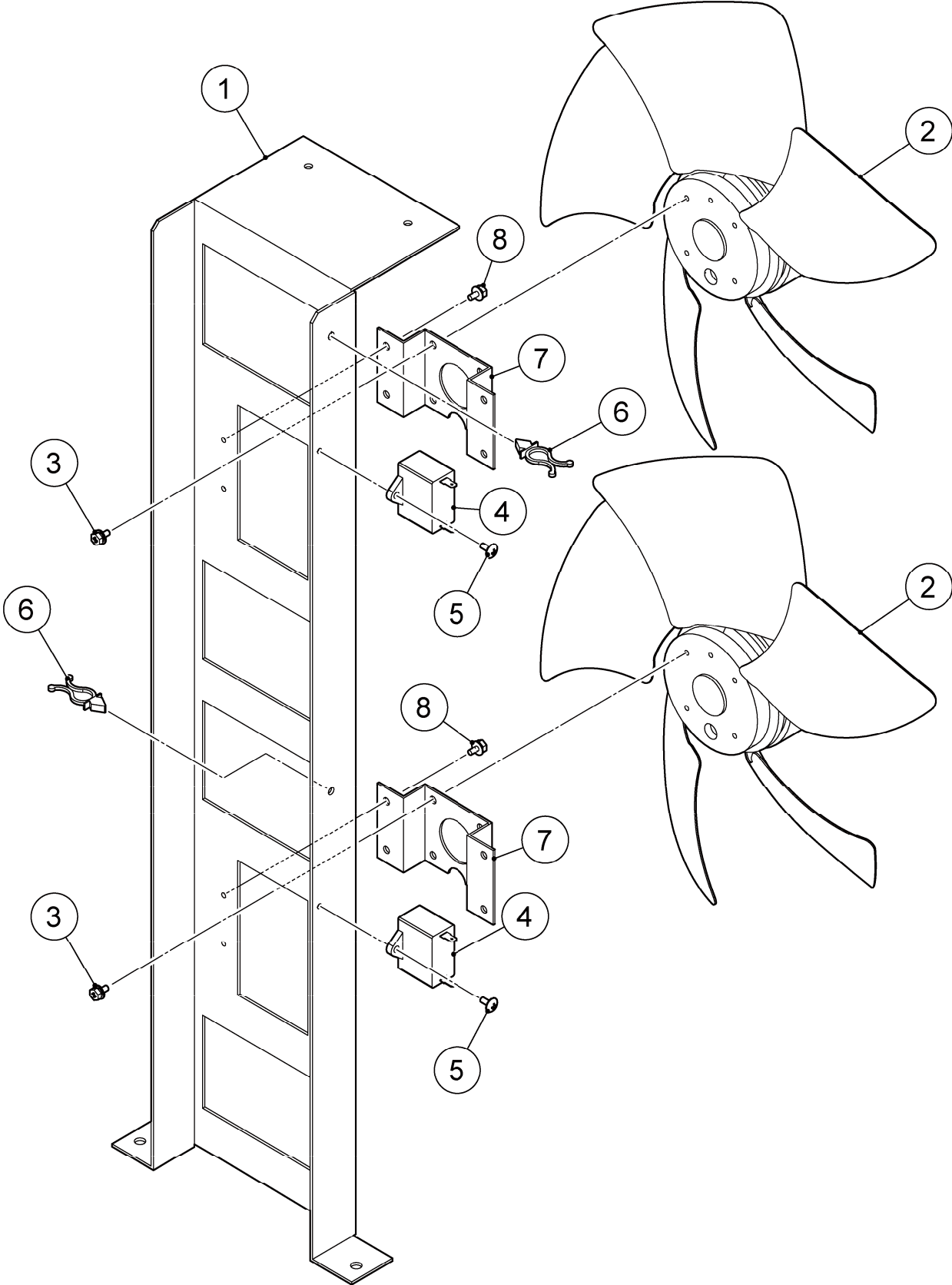

HE

MODEL: FM-480AKE-HC(-SB)		TITLE: M. FAN MOTOR ASSY						
FM-480AKE-HCN(-SB)								
INDEX NO.	DESCRIPTION	MATERIAL OR MODEL NUMBER	PART NUMBER	REQ'D NUMBER				
				B-1 D-0	D-1 E-1	E-2		
1	BRACKET - FAN MOTOR		377284M01	1	1	1		
2	FAN MOTOR		P02394-01	2	2	2		
3	HEX HEAD BOLT (SPRING WASHER AND FLAT WASHER)		FBK0408S0	8	8	8		
4	CAPACITOR		P01865-01	2	2	2		
5	TRUSS HEAD SCREW		FST0408F0	2	2	2		
6	WIRE RETAINER	No.249	427902-03	2	2	2		
7	BRACKET (B) - FAN MOTOR		476680M01	2	2	2		
8	HEX HEAD BOLT (SPRING WASHER AND FLAT WASHER)		FBK0408S0	8	8	8		

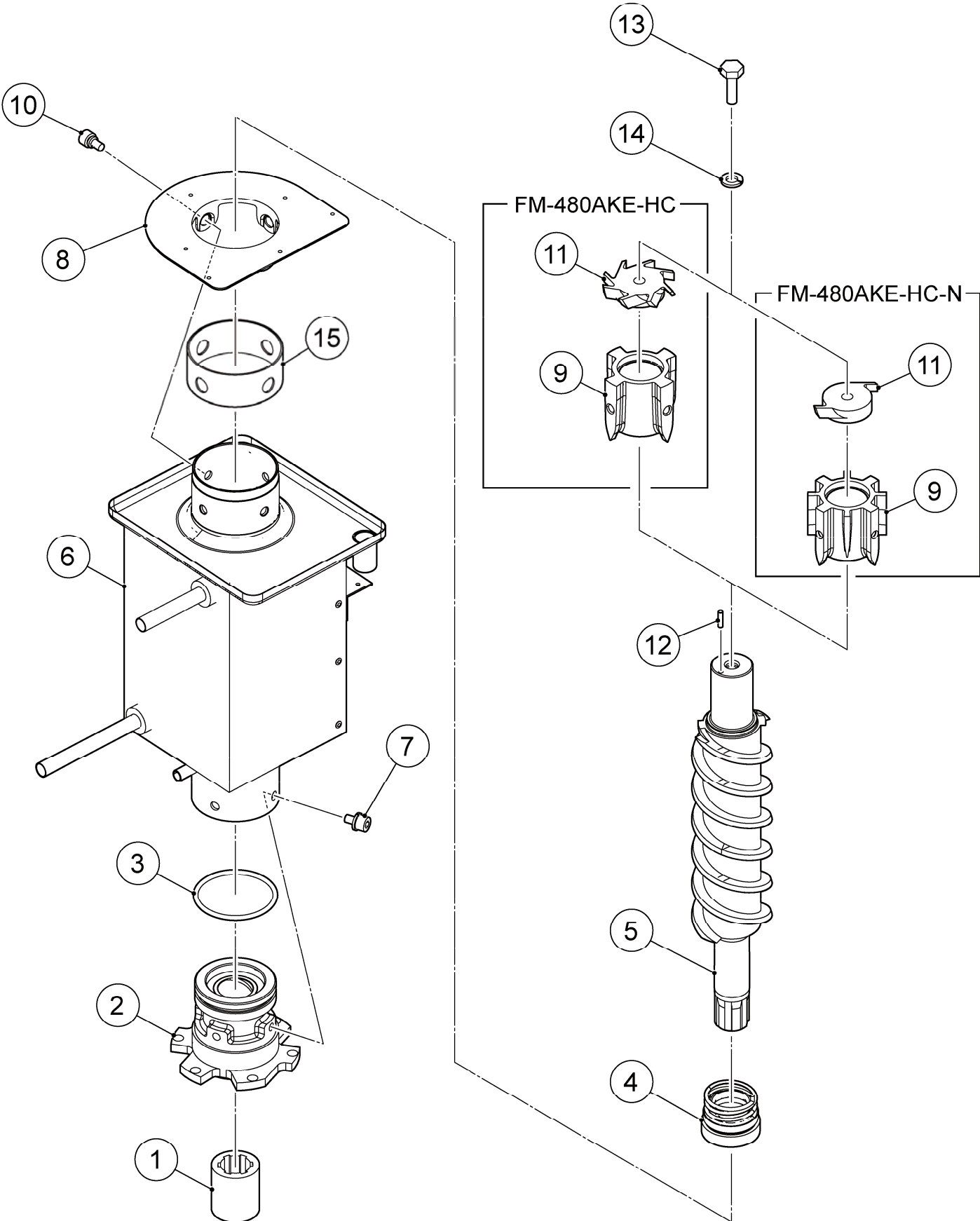

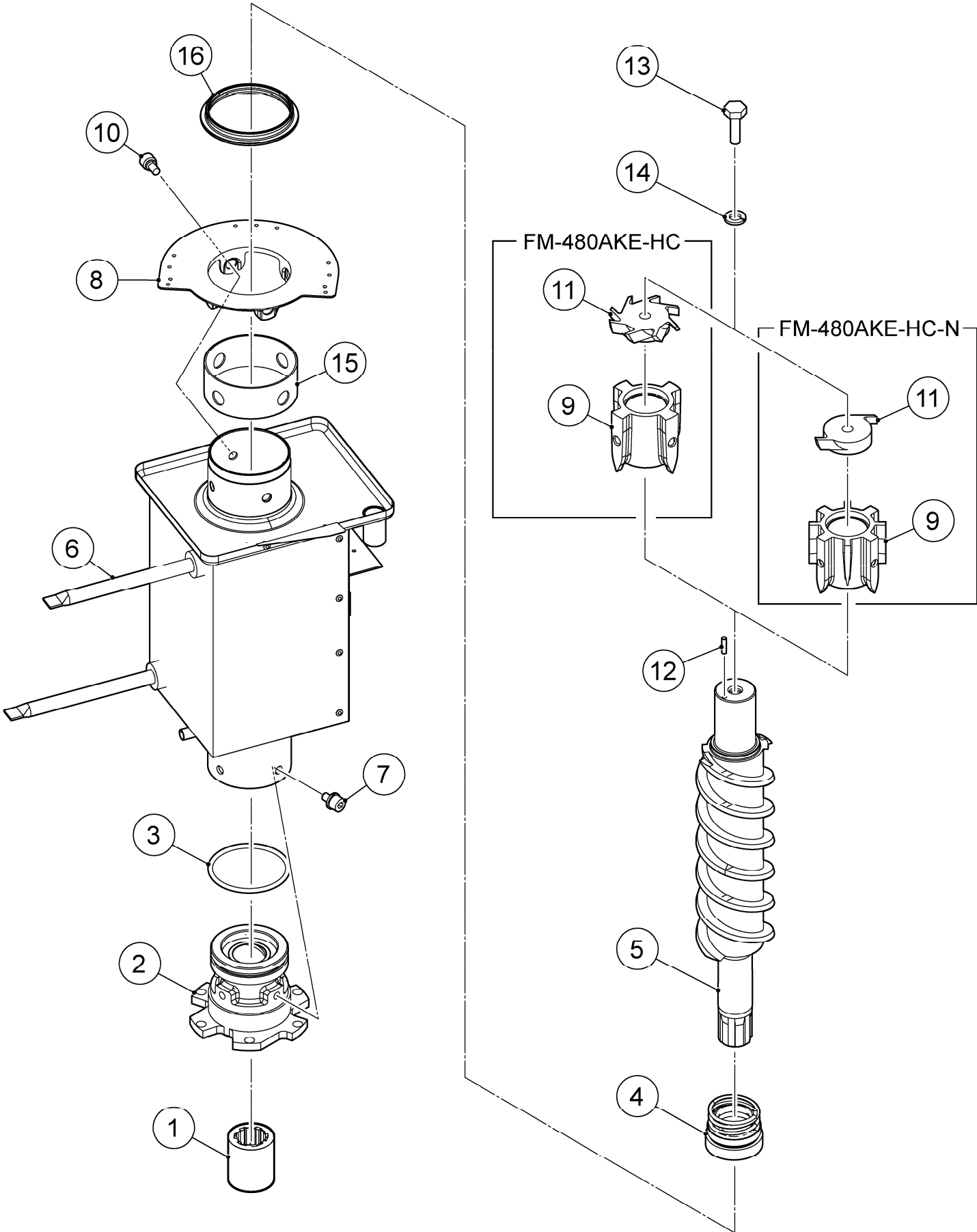

HE

MODEL: FM-480AKE-HC(-SB)		TITLE: N. EVAPORATOR ASSY						
FM-480AKE-HCN(-SB)								
INDEX NO.	DESCRIPTION	MATERIAL OR MODEL NUMBER	PART NUMBER	REQ'D NUMBER				
				B-1 D-0	D-1 E-1	E-2		
1	COUPLING		414137-01	1	1	1		
2	BEARING (LOWER)		206657G02	1	1	1		
3	O-RING		7616-G065	1	1	1		
4	MECHANICAL SEAL		432492-01	1	1	1		
5	AUGER		120863G02	1	1	1		
6	EVAPORATOR		258973G01	1	-	-		
			264134G01	-	1	1		
7	SCREW		P01719-01	4	4	4		
8	FLANGE		352713-01	1	-	-		
			372207M01	-	1	1		
9	EXTRUDING HEAD - 70F		327097G03	1	1	1		
	EXTRUDING HEAD - 70N	NUGGET F087-C106, F087-C107	216531G02	1	1	1		
10	SEAL BOLT - M8		P01768-01	4	4	4		
11	CUTTER		317071-02	1	1	1		
			NUGGET F087-C106, F087-C107	327145-01	1	1	1	
12	PIN		713S-0416	1	1	1		
13	SCREW - BOLT		458101-01	1	1	1		
14	SPRING WASHER		FWSP10S0	1	1	1		
15	BELT HEATER	NUGGET F087-C106, F087-C107	P03243-01	1	1	1		
16	PACKING - SPOUT		473494R01	-	1	1		

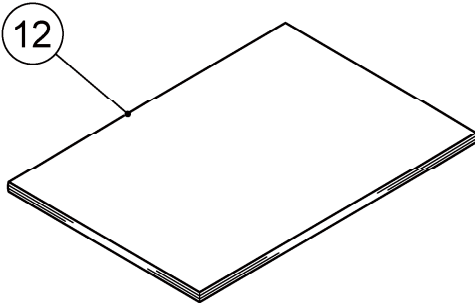
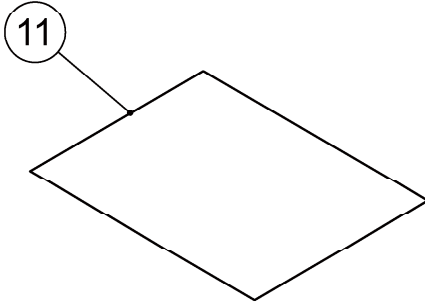
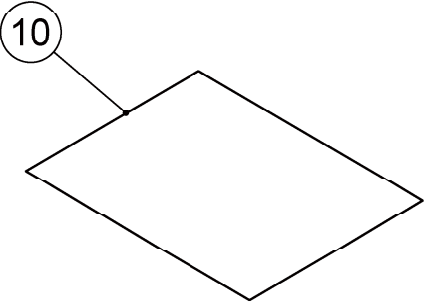
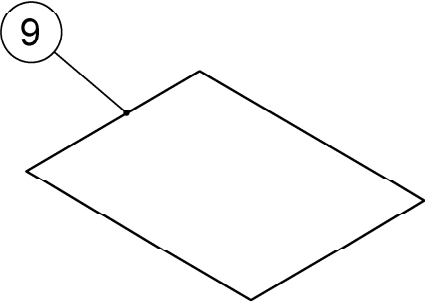
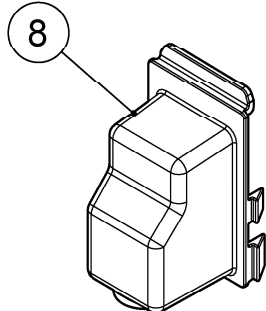
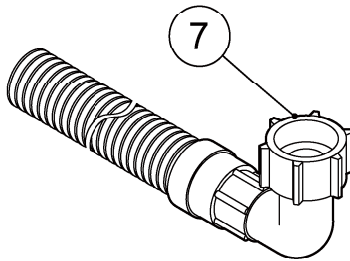
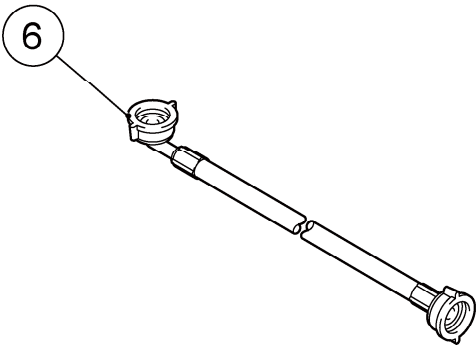
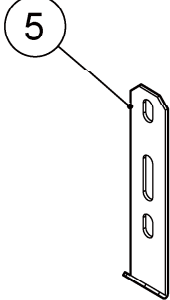
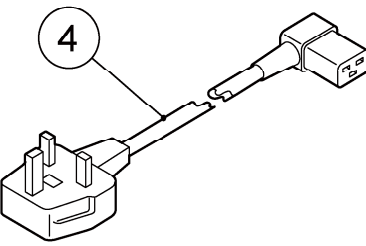
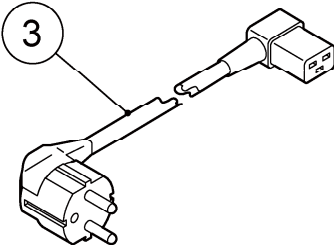
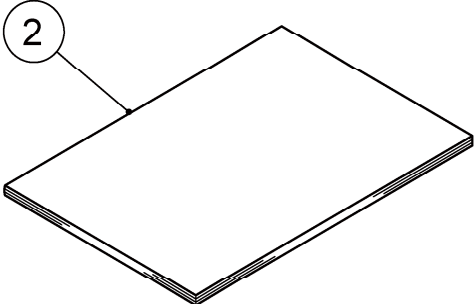
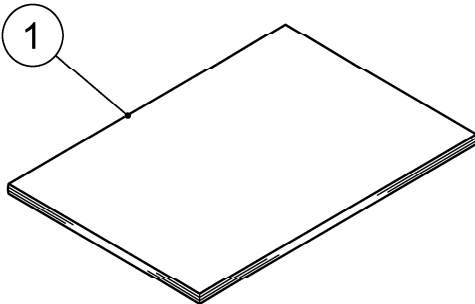

HE

MODEL: FM-480AKE-HC(-SB)		TITLE: P. ACCESSORIES						
FM-480AKE-HCN(-SB)								
INDEX NO.	DESCRIPTION	MATERIAL OR MODEL NUMBER	PART NUMBER	REQ'D NUMBER				
				B-1 D-0	D-1 E-1	E-2		
1	INSTRUCTION MANUAL		L1F087202	1	1	1		
2	INSTALLATION MANUAL		L2F087201	1	-	-		
			L2F087203	-	1	1		
3	POWER SUPPLY CORD	CONT Plug	P03362-01	1	1	1		
4	POWER SUPPLY CORD	UK Plug	P03363-01	1	1	1		
5	UNIVERSAL BRACE		4A0363-01	2	2	2		
6	INLET HOSE		P03534-01	1	1	1		
7	OUTLET HOSE		452365-01	1	1	1		
8	COVER - CONNECTOR		2X0271P01	1	1	1		
9	PE STANDARD BAG	No.12 230*340	7V90-0012	1	1	1		
10	POLYETHYLENE BAG (300*450)	No.15 300*450	7V90-0015	1	1	1		
11	PE BAG (STANDARD)		7V90-0020	1	1	1		
12	INSTRUCTION MANUAL		122234L01	1	1	1		